

Specifications Guide

Agilent Technologies ESA-L Series Spectrum Analyzers

This manual provides documentation for the following instruments:

Agilent Technologies
E4403B (9 kHz - 6.7 GHz)
E4408B (9 kHz - 26.5 GHz)
E4411B (9 kHz - 1.5 GHz)



Agilent Technologies

Manufacturing Part Number: E4403-90013

Printed in USA

November 2000

Supersedes: E4401-90193

© Copyright 2000 Agilent Technologies

The information contained in this document is subject to change without notice.

Agilent Technologies makes no warranty of any kind with regard to this material, including but not limited to, the implied warranties of merchantability and fitness for a particular purpose. Agilent Technologies shall not be liable for errors contained herein or for incidental or consequential damages in connection with the furnishing, performance, or use of this material.

The following safety symbols are used throughout this manual. Familiarize yourself with the symbols and their meaning before operating this instrument.

WARNING

***Warning* denotes a hazard. It calls attention to a procedure which, if not correctly performed or adhered to, could result in injury or loss of life. Do not proceed beyond a warning note until the indicated conditions are fully understood and met.**

WARNING

This is a Safety Class 1 Product (provided with a protective earthing ground incorporated in the power cord). The mains plug shall only be inserted in a socket outlet provided with a protected earth contact. Any interruption of the protective conductor inside or outside of the product is likely to make the product dangerous. Intentional interruption is prohibited.

WARNING

If this product is not used as specified, the protection provided by the equipment could be impaired. This product must be used in a normal condition (in which all means for protection are intact) only.

CAUTION

Caution denotes a hazard. It calls attention to a procedure that, if not correctly performed or adhered to, could result in damage to or destruction of the instrument. Do not proceed beyond a caution sign until the indicated conditions are fully understood and met.

WARNING **This is a Safety Class 1 Product (provided with a protective earthing ground incorporated in the power cord. The mains plug shall only be inserted in a socket outlet provided with a protective earth contact. Any interruption of the protective conductor inside or outside of the product is likely to make the product dangerous. Intentional interruption is prohibited.**

WARNING **If this product is not used as specified, the protection provided by the equipment could be impaired. This product must be used in a normal condition (in which all means for protection are intact) only.**

CAUTION Always use the three-prong ac power cord supplied with this product. Failure to ensure adequate earth grounding by not using this cord may cause product damage.

CAUTION This instrument has autoranging line voltage input, be sure the supply voltage is within the specified range.

Warranty

This Agilent Technologies instrument product is warranted against defects in material and workmanship for a period of one year from date of shipment. During the warranty period, Agilent Technologies Company will, at its option, either repair or replace products which prove to be defective.

For warranty service or repair, this product must be returned to a service facility designated by Agilent Technologies. Buyer shall prepay shipping charges to Agilent Technologies and Agilent Technologies shall pay shipping charges to return the product to Buyer. However, Buyer shall pay all shipping charges, duties, and taxes for products returned to Agilent Technologies from another country.

Agilent Technologies warrants that its software and firmware designated by Agilent Technologies for use with an instrument will execute its programming instructions when properly installed on that instrument. Agilent Technologies does not warrant that the operation of the instrument, or software, or firmware will be uninterrupted or error-free.

LIMITATION OF WARRANTY

The foregoing warranty shall not apply to defects resulting from improper or inadequate maintenance by Buyer, Buyer-supplied software or interfacing, unauthorized modification or misuse, operation outside of the environmental specifications for the product, or improper site preparation or maintenance.

NO OTHER WARRANTY IS EXPRESSED OR IMPLIED. AGILENT TECHNOLOGIES SPECIFICALLY DISCLAIMS THE IMPLIED WARRANTIES OF MERCHANTABILITY AND FITNESS FOR A PARTICULAR PURPOSE.

EXCLUSIVE REMEDIES

THE REMEDIES PROVIDED HEREIN ARE BUYER'S SOLE AND EXCLUSIVE REMEDIES. AGILENT TECHNOLOGIES SHALL NOT BE LIABLE FOR ANY DIRECT, INDIRECT, SPECIAL, INCIDENTAL, OR CONSEQUENTIAL DAMAGES, WHETHER BASED ON CONTRACT, TORT, OR ANY OTHER LEGAL THEORY.

Where to Find the Latest Information

Documentation is updated periodically. For the latest information about Agilent Spectrum Analyzers, including firmware upgrades and application information, please visit the following Internet URL:
<http://www.agilent.com/go/esa>.

Contents

1. Agilent E4403B Specifications and Characteristics

About This Chapter	1-2
Frequency	1-4
Amplitude	1-8
Options	1-15
Tracking Generator (Option 1DN)	1-15
General	1-19
Inputs and Outputs	1-23
Front Panel	1-23
Rear Panel	1-24
Regulatory Information	1-28
Declaration of Conformity	1-29

2. Agilent E4408B Specifications and Characteristics

About This Chapter	2-2
Frequency	2-4
Amplitude	2-9
Options	2-18
Tracking Generator (Option 1DN)	2-18
General	2-22
Inputs and Outputs	2-26
Front Panel	2-26
Rear Panel	2-27
Regulatory Information	2-31
Declaration of Conformity	2-32

3. Agilent E4411B Specifications and Characteristics

About This Chapter	3-2
Frequency	3-4
Amplitude	3-8
Options	3-17
Tracking Generator (Option 1DN or 1DQ)	3-17
General	3-21
Inputs and Outputs	3-25
Internal	3-25
Front Panel	3-25
Rear Panel	3-26
Regulatory Information	3-30
Declaration of Conformity	3-31

About This Chapter

This chapter contains specifications and characteristics for the Agilent E4403B spectrum analyzer. The distinction between specifications and characteristics is described as follows.

- Specifications describe the performance of parameters covered by the product warranty. (The temperature range is 0 °C to 55 °C, unless otherwise noted.)
- Characteristics describe product performance that is useful in the application of the product, but is not covered by the product warranty.
- Typical performance describes additional product performance information that is not covered by the product warranty. It is performance beyond specification that 80% of the units exhibit with a 95% confidence level over the temperature range 20 to 30 °C. Typical performance does not include measurement uncertainty.
- Nominal values indicate the expected performance, or describe product performance that is useful in the application of the product, but is not covered by the product warranty.

The following conditions must be met for the analyzer to meet its specifications.

- The analyzer is within the one year calibration cycle.
- If **Auto Align All** is selected:
 - After 2 hours of storage within the operating temperature range.
 - 5 minutes after the analyzer is turned on with sweep times less than 4 seconds.
 - After the front-panel amplitude reference is connected to the INPUT, and **Align Now RF** has been run, after the analyzer is turned on. And, once every 24 hours, or if ambient temperature changes more than 30 °C.
- If **Auto Align Off** is selected:
 - When the analyzer is at a constant temperature, within the operating temperature range, for a minimum of 90 minutes.
 - After the analyzer is turned on for a minimum of 90 minutes, the front panel amplitude reference has been connected to the INPUT, and **Align Now All** has been run.
 - When **Align Now All** is run:
 - Every hour

- If the ambient temperature changes more than 3 °C
- If the 10 MHz reference changes
- When **Align Now RF** is run (with the front-panel amplitude reference connected to the INPUT):
 - Every 24 hours
 - If the ambient temperature changes more than 30 °C
- If **Auto Align All but RF** is selected:
 - When the analyzer is at a constant temperature, within the operating temperature range, for a minimum of 90 minutes.
 - After the analyzer is turned on for a minimum of 90 minutes, the front panel amplitude reference has been connected to the INPUT, and **Align Now RF** has been run.
 - When **Align Now RF** is run (with the front-panel amplitude reference connected to the INPUT):
 - Every hour
 - If the ambient temperature changes more than 3 °C

Frequency

	Specifications	Supplemental Information
Frequency Range	9 kHz to 3 GHz	

	Specifications	Supplemental Information
Frequency Reference		
Aging Rate	$\pm 2 \times 10^{-6}$ /year	$\pm 1.0 \times 10^{-7}$ /day, characteristic
Settability	$\pm 5 \times 10^{-7}$	
Temperature Stability	$\pm 5 \times 10^{-6}$	

	Specifications	Supplemental Information
Frequency Readout Accuracy (Start, Stop, Center, Marker)	$\pm((\text{frequency indication} \times \text{frequency reference error}^a) + 0.75\% \text{ of span} + 15\% \text{ of RBW} + 10 \text{ Hz})$	

a. Frequency reference error = (aging rate \times period of time since adjustment + settability + temperature stability).

	Specifications	Supplemental Information
Marker Frequency Counter		
Resolution	Selectable from 1 Hz to 100 kHz	
Accuracy ^a	$\pm(\text{marker frequency} \times \text{frequency reference error}^b + \text{counter resolution})$	

a. Marker level to displayed noise level > 25 dB, RBW/ Span \geq 0.002, frequency offset = 0 Hz.

b. Frequency reference error = (aging rate \times period of time since adjustment + settability + temperature stability).

	Specifications	Supplemental Information
Frequency Span		
Range	0 Hz (zero span), 100 Hz to 3 GHz	
Resolution	2 Hz	
Accuracy	±1.0% of span	

	Specifications	Supplemental Information
Sweep Time		
Range	4 ms to 4000 s ^a	
Tracking Generator On (Option 1DN)		50 ms is the minimum sweep time
Accuracy (Span = 0 Hz)		
4 ms to 4000 s ^a	±1%	
Sweep Trigger ^b	Free Run, Single, Line, Video, External, Delayed, Offset ^c	
Delayed Trigger ^d		
Range	1 μs to 400 s	
Resolution	$\frac{\text{delay in seconds}}{65000}$ rounded up to nearest μs	
Accuracy	±(500 ns + (0.01% of delay))	
Offset Trigger ^c		
Resolution	$\frac{\text{sweep time}}{400}$	
Range	±327 ms to ±323 ks	Where ST = sweep time $\frac{-32766 \times ST}{400}$ to $\frac{32365 \times ST}{400}$

- a. For firmware revisions prior to A.04.00, 5 ms to 2000 s.
- b. Auto align is suspended in video, external, and delayed trigger modes while waiting for a trigger event to occur.
- c. For firmware revision A.04.00 or later.
- d. Delayed trigger is available with line and external trigger.

	Specifications	Supplemental Information
Sweep (trace) Points	401	

	Specifications	Supplemental Information
Resolution Bandwidth (RBW)		
Range		
–3 dB bandwidth	1 kHz to 3 MHz, in 1-3-10 sequence, 5 MHz	
–6 dB bandwidth (EMI)	9 kHz and 120 kHz	
Accuracy		
1 kHz to 3 MHz RBW	±15%	
5 MHz RBW	±30%	
Shape		
1 kHz to 5 MHz RBW		Synchronously tuned four poles, approximately Gaussian shape
Selectivity (60 dB/3 dB bandwidth ratio)		
1 kHz to 5 MHz RBW		<15:1, characteristic

	Specifications	Supplemental Information
Video Bandwidth (VBW) (–3 dB)		
Range	30 Hz to 1 MHz in 1-3-10 sequence	3 MHz, characteristic
Accuracy		±30%, characteristic
Shape		Post detection, single pole low-pass filter used to average displayed noise

	Specifications	Supplemental Information
Stability		
Noise Sidebands (Offset from CW signal with 1 kHz RBW, 30 Hz VBW and sample detector)		
≥10 kHz	≤ -90 dBc/Hz	≤ -94 dBc/Hz, typical
≥20 kHz	≤ -100 dBc/Hz	≤ -105 dBc/Hz, typical
≥30 kHz	≤ -106 dBc/Hz	≤ -112 dBc/Hz, typical
≥100 kHz	≤ -119 dBc/Hz	≤ -122 dBc/Hz, typical
Residual FM		
1 kHz RBW, 1 kHz VBW	≤150 Hz p-p in 100 ms	
System-Related Sidebands, offset from CW signal		
≥30 kHz	≤ -65 dBc	

Noise Sidebands Normalized to 1 Hz Versus Offset from Carrier

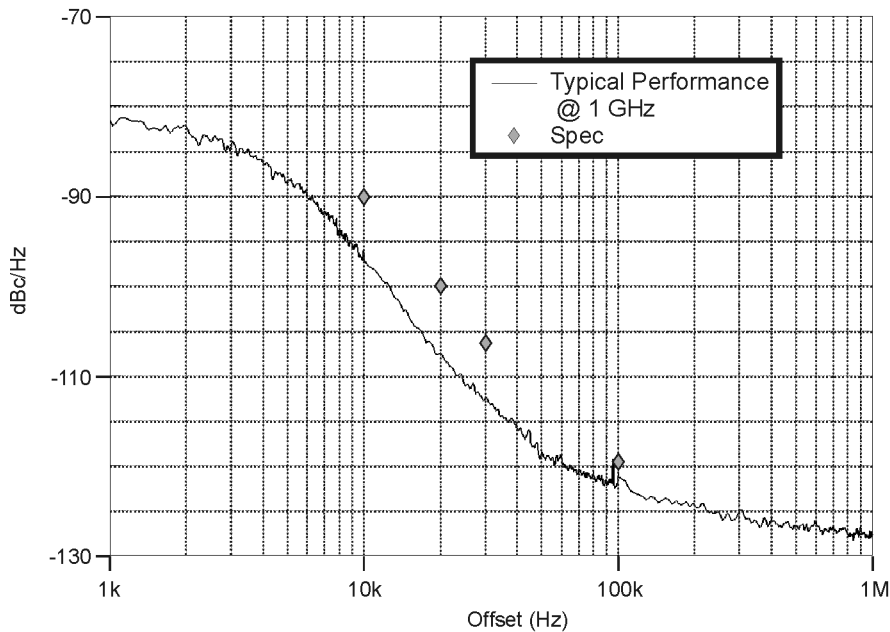

wi76b

Amplitude

Amplitude specifications do not apply for the negative peak detector mode.

	Specifications	Supplemental Information
Measurement Range	Displayed Average Noise Level to Maximum Safe Input Level	
Input Attenuator Range	0 to 65 dB, in 5 dB steps	0 to 75 dB, in 5 dB steps, characteristic

	Specifications	Supplemental Information
Maximum Safe Input Level		
Average Continuous Power (Input attenuator setting ≥ 5 dB)	+30 dBm (1 W)	
Peak Pulse Power (for <10 μ sec pulse width, $<1\%$ duty cycle, and input attenuation ≥ 30 dB)	+50 dBm (100 W)	
dc	100 Vdc	

	Specifications	Supplemental Information
1 dB Gain Compression		
Total power at input mixer ^{a,b} 50 MHz to 3.0 GHz	0 dBm	

a. Mixer power level (dBm) = input power (dBm) – input attenuation (dB).

b. For resolution bandwidths 1 kHz to 30 kHz, the maximum input signal amplitude must be \leq reference level +10 dB.

	Specifications	Supplemental Information
<p>Displayed Average Noise Level</p> <p>(Input terminated, 0 dB attenuation, sample detector, Reference Level = -70 dBm)</p> <p>1 MHz to 10 MHz</p> <p>10 MHz to 1.0 GHz</p> <p>1.0 GHz to 2.0 GHz</p> <p>2.0 GHz to 3.0 GHz</p>	<p>1 kHz RBW, 30 Hz VBW</p> <p>≤ -117 dBm</p> <p>≤ -116 dBm</p> <p>≤ -114 dBm</p>	<p>1 kHz RBW, 30 Hz VBW</p> <p>≤ -117 dBm, characteristic</p>

	Specifications	Supplemental Information
<p>Display Range</p> <p>Log Scale</p> <p>Linear Scale</p> <p>Scale Units</p>	<p>Ten divisions displayed; 0.1, 0.2, 0.5 dB/division and 1 to 20 dB/division in 1 dB steps</p> <p>Calibrated 0 to -85 dB from Reference Level</p> <p>Ten divisions</p> <p>dBm, dBmV, dBμV, V, and W</p>	

	Specifications	Supplemental Information
<p>Marker Readout Resolution</p> <p>Log scale</p> <p>0 to -85 dB from ref level</p> <p>Linear scale</p>	<p>0.04 dB</p> <p>0.01% of Reference Level</p>	

	Specifications	Supplemental Information
Frequency Response Absolute ^a /Relative 10 dB attenuation 9 kHz to 3.0 GHz 20 to 30 °C 0 to 55 °C	 ±0.5 dB ±1.0 dB	

a. Absolute flatness values are referenced to the amplitude at 50 MHz.

	Specifications	Supplemental Information
Input Attenuation Switching Uncertainty at 50 MHz Attenuator Setting 0 dB to 5 dB 10 dB 15 dB 20 to 65 dB attenuation	 ±0.3 dB Reference ±0.3 dB ±(0.1 dB + 0.01 × Attenuator Setting)	

Attenuation Accuracy Relative to the 10 dB Attenuator Setting, Characteristic		
	Frequency Range	
Attenuation	dc-3.0 GHz	
0 dB	±0.3 dB	
5 dB	±0.3 dB	
10 dB	Reference	
15 dB	±0.4 dB	
20 dB	±0.4 dB	
25 dB	±0.5 dB	
30 dB	±0.5 dB	
35 dB	±0.6 dB	
40 dB	±0.6 dB	
45 dB	±0.7 dB	

Attenuation Accuracy Relative to the 10 dB Attenuator Setting, Characteristic		
	Frequency Range	
Attenuation	dc-3.0 GHz	
50 dB	±0.7 dB	
55 dB	±0.9 dB	
60 dB	±0.9 dB	
65 dB	±1.0 dB	

	Specifications	Supplemental Information
Absolute Amplitude Accuracy		
At reference settings ^a	±0.4 dB	
Overall Amplitude Accuracy ^b		
20 to 30 °C	± (0.6 dB + Absolute Frequency Response)	

- a. Settings are: reference level -20 dBm; input attenuation 10 dB; center frequency 50 MHz; RBW 1 kHz; VBW 1 kHz; scale linear or log; span 2 kHz; sweep time coupled, signal at reference level.
- b. For reference level 0 to -50 dBm; input attenuation 10 dB; RBW 1 kHz; VBW 1 kHz; scale log, log range 0 to -50 dB from reference level; sweep time coupled; signal input 0 to -50 dBm; span ≤20 kHz.

	Specifications	Supplemental Information
RF Input VSWR (at tuned frequency)		
Attenuator setting 0 dB		
100 kHz to 3 GHz		≤3.0:1, characteristic
Attenuator setting 5 dB		
100 kHz to 3 GHz		≤1.6:1, characteristic
Attenuator setting 10 to 65 dB		
9 kHz to 100 kHz		≤2.0:1, characteristic
100 kHz to 3 GHz		≤1.4:1, characteristic

	Specifications	Supplemental Information
Auto Alignment^a Sweep-to-sweep variation		±0.1 dB, characteristic

a. Set Auto Align to Off and use Align Now, All to eliminate this variation.

	Specifications	Supplemental Information
Resolution Bandwidth Switching Uncertainty (at Reference Level)		
1 kHz RBW	Reference	
3 kHz to 3 MHz RBW	±0.3 dB	
5 MHz RBW	±0.6 dB	

	Specifications	Supplemental Information
Reference Level		
Range	-149.9 dBm to maximum mixer level + attenuator setting	
Resolution		
Log Scale	±0.1 dB	
Linear Scale	±0.12% of Reference Level	
Accuracy (at a fixed frequency, a fixed attenuator, and referenced to -30 dBm)		
Reference Level (dBm) – input attenuator setting (dB)		
-10 dBm to > -60 dBm	±0.3 dB	
-60 dBm to > -85 dBm	±0.5 dB	
-85 dBm to -90 dBm	±0.7 dB	

	Specifications	Supplemental Information
Display Scale Switching Uncertainty		
Switching between Linear and Log	±0.15 dB at Reference Level	
Log Scale Switching	No error	

	Specifications	Supplemental Information
Display Scale Fidelity		
Log Maximum Cumulative 0 to 85 dB Below reference level	$\pm(0.3 \text{ dB} + 0.01 \times \text{dB from reference level})$	
Log Incremental Accuracy 0 to 80 dB below reference level	$\pm 0.4 \text{ dB}/4 \text{ dB}$	
Linear Accuracy	$\pm 2\%$ of Reference Level	

	Specifications	Supplemental Information
Spurious Responses		
Second Harmonic Distortion		
Input Signal		
10 MHz to 500 MHz	$< -60 \text{ dBc}$ for -30 dBm signal at input mixer ^a	+30 dBm SHI (second harmonic intercept)
500 MHz to 1.5 GHz	$< -70 \text{ dBc}$ for -30 dBm signal at input mixer ^a	+40 dBm SHI
Third Order Intermodulation Distortion		
10 MHz to 100 MHz		+5 dBm TOI (third order intercept), characteristic
100 MHz to 3 GHz	$< -75 \text{ dBc}$ for two -30 dBm signals at input mixer ^a and $>50 \text{ kHz}$ separation	+7.5 dBm TOI
Other Input Related Spurious		
$>30 \text{ kHz}$ offset	$< -65 \text{ dBc}$ for -20 dBm signal at input mixer ^a	

a. Mixer power level (dBm) = input power (dBm) – input attenuation (dB)

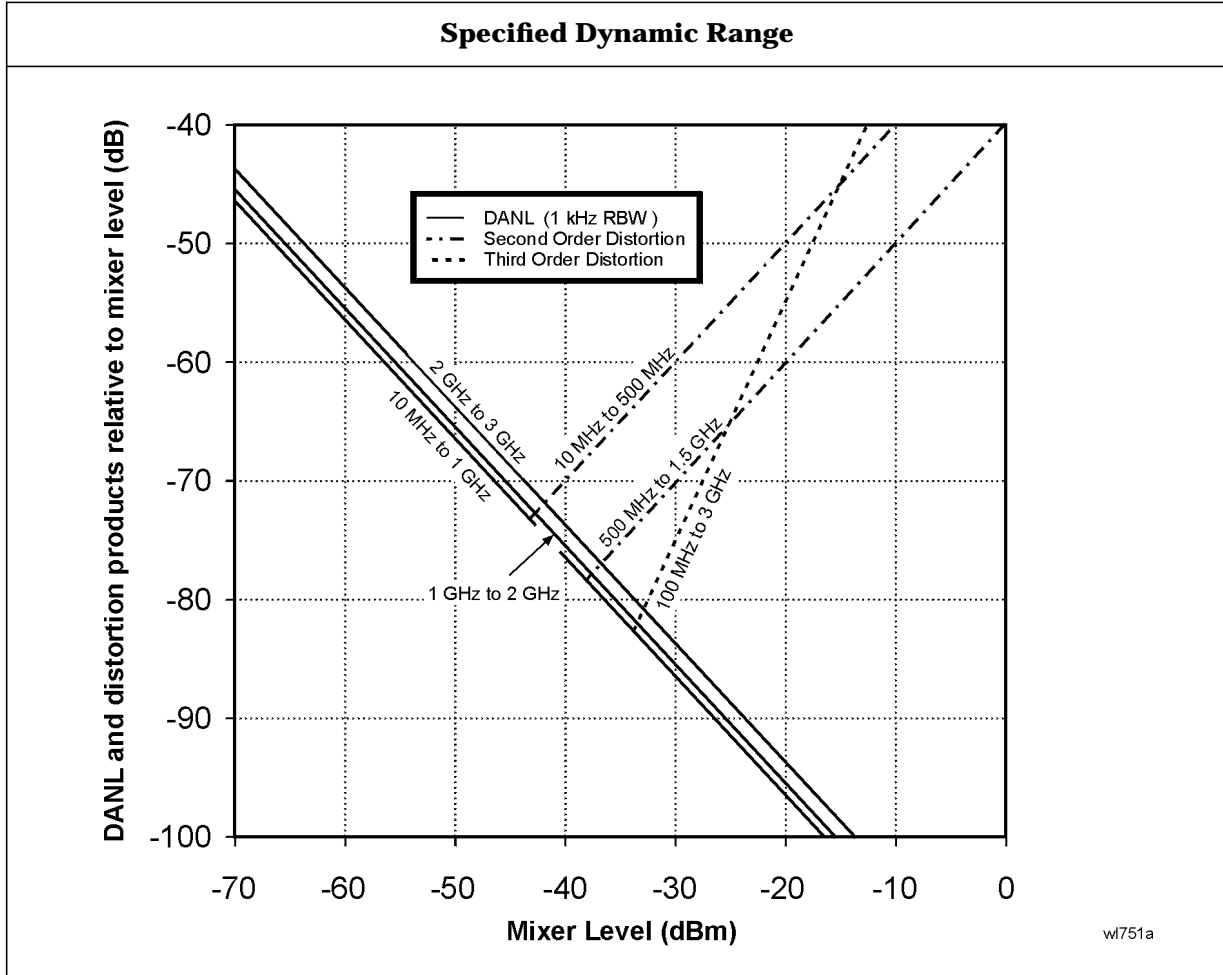

	Specifications	Supplemental Information
<p>Residual Responses (Input terminated and 0 dB attenuation)</p> <p>150 kHz to 3 GHz</p>	<p>< -90 dBm</p>	

Options

Tracking Generator (Option 1DN)

The spectrum analyzer/tracking generator combination will meet its specification after a cable (8120-5148) and adapter are connected between RF OUT and INPUT and **Align Now**, TG has been run.

	Specifications	Supplemental Information
Warmup	5 minutes	

	Specifications	Supplemental Information
Output Frequency Range	9 kHz to 3.0 GHz	

	Specifications	Supplemental Information
Output Power Level		
Range	-2 to -66 dBm	
Resolution	0.1 dB	
Absolute Accuracy (at 50 MHz with coupled source attenuator, referenced to -20 dBm)	± 0.75 dB	
Vernier		
Range	8 dB	
Accuracy (with coupled source attenuator, 50 MHz, -20 dBm)		
Incremental	± 0.2 dB/dB	
Cumulative	± 0.5 dB, total	
Output Attenuator Range	0 to 56 dB in 8 dB steps	

	Specifications	Supplemental Information
Maximum Safe Reverse Level		+30 dBm (1 W), 50 Vdc, characteristic

	Specifications	Supplemental Information
Output Power Sweep		
Range	(-10 to -2 dBm) – (Source Attenuator Setting)	
Resolution	0.1 dB	
Accuracy (zero span)	<1 dB peak-to-peak	

	Specifications	Supplemental Information
Output Flatness		
Referenced to 50 MHz, -20 dBm		
9 kHz to 10 MHz	±3 dB	
10 MHz to 3 GHz	±2 dB	

	Specifications	Supplemental Information
Spurious Outputs		
(-2 dBm output)		
Harmonic Spurs		
TG Output 9 kHz to 20 kHz	≤ -15 dBc	
TG Output 20 kHz to 3 GHz	≤ -25 dBc	
Non-harmonic Spurs		
TG Output 9 kHz to 2 GHz	≤ -27 dBc	
TG Output 2 GHz to 3 GHz	≤ -23 dBc	
LO Feedthrough		
LO Frequency 3.921409 GHz to 6.9214 GHz	≤ -16 dBm	

	Specifications	Supplemental Information
Dynamic Range	Maximum Output Power Level – Displayed Average Noise Level	

	Specifications	Supplemental Information
Output Tracking		
Drift		1.5 kHz/5 minute, characteristic
Swept Tracking Error		Usable in 1 kHz RBW after 5 minutes of warmup

	Specifications	Supplemental Information
RF Power-Off Residuals		
9 kHz to 3 GHz		< –120 dBm, characteristic

	Specifications	Supplemental Information
Output Attenuator Repeatability		
9 kHz to 300 MHz		±0.1 dB, characteristic
300 MHz to 2 GHz		±0.2 dB, characteristic
2 GHz to 3 GHz		±0.3 dB, characteristic

	Specifications	Supplemental Information
Output VSWR		
0 dB attenuation		<2.0:1, characteristic
≥ 8 dB attenuation		<1.5:1, characteristic

	Specifications	Supplemental Information
Output Attenuator Accuracy		
0 dB		±0.5 dB, characteristic
8 dB		±0.5 dB, characteristic
16 dB	Reference	
24 dB		±0.5 dB, characteristic

	Specifications	Supplemental Information
32 dB		±0.6 dB, characteristic
40 dB		±0.8 dB, characteristic
48 dB		±1.0 dB, characteristic
56 dB		±1.1 dB, characteristic

Tracking Generator Output Accuracy
Relative Accuracy (Referred to -20 dBm) = Output Attenuator Accuracy + Vernier Accuracy + Output Flatness
Absolute Accuracy = Relative Accuracy (Referred to -20 dBm) + Absolute Accuracy at 50 MHz

General

	Specifications	Supplemental Information
Temperature Range		
Operating	0 to 55 °C	Floppy disk 10 to 40 °C
Storage	-40 to 75 °C	

	Specifications	Supplemental Information
Audible Noise (ISO 7779)		
Sound Pressure at 25 °C		<40 dBa, (<4.6 Bels power)

	Specifications	Supplemental Information
Military Specification	Has been type tested to the environmental specifications of MIL-PRF-28800F class 3.	

	Specifications	Supplemental Information
EMI Compatibility	Conducted and radiated emission is in compliance with CISPR Pub. 11/1990 Group 1 Class A.	

	Specifications	Supplemental Information
Immunity Testing		
Radiated Immunity		Testing was done at 3 V/m according to IEC 801-3/1984. When the analyzer tuned frequency is identical to the immunity test signal frequency there may be signals of up to -60 dBm displayed on the screen.
Electrostatic Discharge		Air discharges of up to 8 kV were applied according to IEC 801-2/1991. Discharges to center pins of any of the connectors may cause damage to the associated circuitry.

	Specifications	Supplemental Information
Power Requirements		
ac Operation		
Voltage, frequency	90 to 132 Vrms, 47 to 440 Hz 195 to 250 Vrms, 47 to 66 Hz	
Power Consumption, On	<300 W	
Power Consumption, Standby	<5 W	
dc Operation		
Voltage	12 to 20 Vdc	
Power Consumption	<200 W	

	Specifications	Supplemental Information
Measurement Speed		
Local Measurement and Display Update rate ^a		≥ 30/s, characteristic
Remote Measurement and GPIB Transfer Rate ^{b,c} (<i>Option A4H</i>)		≥30/s, characteristic
RF Center Frequency Tune, Measure, and GPIB Transfer Time ^{bd} (<i>Option A4H</i>)		≤ 90 ms, characteristic

- a. Factory preset, auto align Off, fixed center frequency, RBW = 1 MHz, and spans >10 MHz and ≤600 MHz.
- b. Display Off (:DISPlay:ENABle OFF), and 32-bit integer data format (:FORMat:DATA INT,32), if *Option A4J* is installed, disable sweep ramp, (:SYSTem:PORTs:IFVSweep:ENABle OFF), markers Off, single sweep, measured with IBM compatible PC with 550 MHz Pentium® III running Windows® NT 4.0, one meter GPIB cable, National Instruments PCI-GPIB card and NI-488.2 DLL.
- c. Factory preset, auto align Off, RBW = 1 MHz, span= 20 MHz, fixed center frequency, average of 100 measurements.
- d. Factory preset, auto align Off, RBW = 1 MHz, span= 20 MHz, and center frequency tune step size = 50 MHz.

	Specifications	Supplemental Information
Data Storage		
Internal		200 Traces or States
External (10 to 40 °C) 3.5" 1.44 MB, MS-DOS® compatible floppy disk		200 Traces or States

	Specifications	Supplemental Information
Demod Tune and Listen		
Demod <i>(Option A4J)</i>	AM	Internal speaker, front-panel earphone jack and front-panel volume control. An uncalibrated demodulated signal is available on the AUX VIDEO OUT connector at the rear panel.

	Specifications	Supplemental Information
Weight (without options)		
Net		15.5 kg (34.2 lb), characteristic
Shipping		27.4 kg (60.4 lb), characteristic

Dimensions

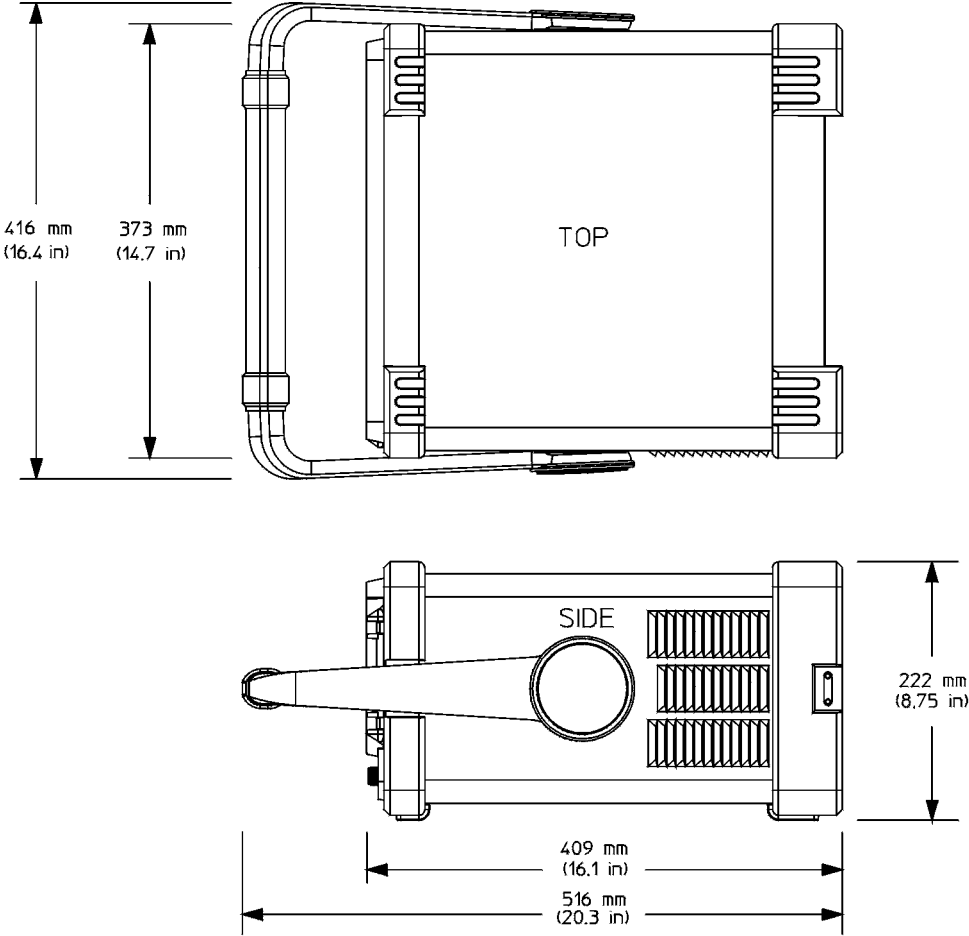

n1742a

Inputs and Outputs

Front Panel

	Specifications	Supplemental Information
INPUT 50 Ω		
Connector	Type-N female	
Impedance		50 Ω , nominal

	Specifications	Supplemental Information
RF OUT 50 Ω, (Option 1DN)		
Connector	Type-N female	
Impedance		50 Ω , nominal

	Specifications	Supplemental Information
AMPTD REF OUT^a		Amplitude Reference
Connector	BNC female	
Impedance		50 Ω , nominal
Frequency		50 MHz
Frequency Accuracy		Frequency reference error ^b
50 Ω Amplitude ^c		-20 dBm, nominal

- Turn the amplitude reference on/off by pressing the keys: **Input/Output**, **Amptd Ref Out**.
- Frequency reference error = (aging rate \times period of time since adjustment + settability + temperature stability).
- The internal amplitude reference actual power is stored internally.

	Specifications	Supplemental Information
PROBE POWER		
Voltage/Current		+15 Vdc, $\pm 7\%$ at 150 mA max., characteristic -12.6 Vdc $\pm 10\%$ at 150 mA max., characteristic

	Specifications	Supplemental Information
EXT KEYBOARD^a		Used for entering screen titles and filenames only. Interface compatible with most IBM-compatible PC keyboards.
Connector	6-pin mini-DIN	

a. The feature is not implemented in firmware revisions prior to A.04.00.

	Specifications	Supplemental Information
Speaker		Front panel knob controls volume

	Specifications	Supplemental Information
Headphone		Front panel knob controls volume
Connector	3.5 mm (1/8 inch) miniature audio jack	
Power Output		0.2 W into 4 Ω , characteristic

Rear Panel

	Specifications	Supplemental Information
10 MHz REF OUT		
Connector	BNC female	
Impedance		50 Ω , nominal
Output Amplitude		>0 dBm, characteristic

	Specifications	Supplemental Information
10 MHz REF IN		
Connector	BNC female	Note: Analyzer noise sidebands and spurious response performance may be affected by the quality of the external reference used.
Impedance		50 Ω , nominal
Input Amplitude Range		-15 to +10 dBm, characteristic
Frequency		10 MHz, nominal

	Specifications	Supplemental Information
GATE TRIG/EXT TRIG IN		
Connector	BNC female	
External Trigger Input		
Trigger Level		Selectable positive or negative edge initiates sweep in EXT TRIG mode (5 V TTL)

	Specifications	Supplemental Information
GATE/HI SWP OUT		
Connector	BNC female	
High Sweep Output		
Level		High = sweep ^a ; Low = retrace (5 V TTL)

a. High sweep may be high longer than the indicated sweep times.

	Specifications	Supplemental Information
VGA OUTPUT		
Connector	VGA compatible, 15-pin mini D-SUB	
Format		VGA (31.5 kHz horizontal, 60 Hz vertical sync rates, non-interlaced) Analog RGB
Resolution	640 \times 480	

	Specifications	Supplemental Information
AUX IF OUT <i>(Option A4J)</i> Connector Frequency Amplitude (for signal at reference level and for reference levels – input attenuation of –10 to –70 dBm) Impedance	BNC female	21.4 MHz, nominal –10 dBm (uncorrected), characteristic 50 Ω, nominal

	Specifications	Supplemental Information
AUX VIDEO OUT <i>(Option A4J)</i> Connector Amplitude Range (into >10 kΩ)	BNC female	0 to 1 V (uncorrected), characteristic

	Specifications	Supplemental Information
HI SWP IN <i>(Option A4J)</i> Connector Input	BNC female	Open collector, low resets and holds the sweep (5 V TTL)

	Specifications	Supplemental Information
HI SWP OUT <i>(Option A4J)</i> Connector Output	BNC female	High = sweep ^a , Low = retrace (5 V TTL)

a. High sweep may be high longer than the indicated sweep times.

	Specifications	Supplemental Information
SWP OUT <i>(Option A4J)</i>		
Connector	BNC female	
Amplitude		0 to +10 V ramp, characteristic

	Specifications	Supplemental Information
GPIB Interface <i>(Option A4H)</i>		
Connector	IEEE-488 bus connector	
GPIB Codes		SH1, AH1, T6, SR1, RL1, PP0, DC1, C1, C2, C3 and C28

	Specifications	Supplemental Information
Serial Interface <i>(Option 1AX)</i>		
Connector	9-pin D-SUB male	RS-232

	Specifications	Supplemental Information
Parallel Interface <i>(Option A4H or 1AX)</i>		Printer port only
Connector	25-pin D-SUB female	

Regulatory Information

CAUTION

This product is designed for use in Installation Category II and Pollution Degree 2 per IEC 1010 and 664 respectively.

NOTE

This product has been designed and tested in accordance with IEC Publication 1010, Safety Requirements for Electronic Measuring Apparatus, and has been supplied in a safe condition. The instruction documentation contains information and warnings which must be followed by the user to ensure safe operation and to maintain the product in a safe condition.



The CE mark is a registered trademark of the European Community (if accompanied by a year, it is the year when the design was proven).



The CSA mark is the Canadian Standards Association safety mark.

ISM 1-A

This is a symbol of an Industrial Scientific and Medical Group 1 Class A product. (CISPR 11, Clause 4)

Declaration of Conformity

DECLARATION OF CONFORMITY

According to ISO/IEC Guide 22 and CEN/CENELEC EN 45014

Manufacturer's Name: Agilent Technologies, Inc.

Manufacturer's Address: 1400 Fountaingrove Parkway
Santa Rosa, CA 95403-1799
USA

Declares that the products

Product Name: Spectrum Analyzer

Model Number: E4401B, E4402B, E4403B, E4404B,
E4405B, E4407B, E4408B, E4411B

Product Options: This declaration covers all options of the above products.

Conform to the following product specifications:

EMC: IEC 61326-1:1997+A1:1998 / EN 61326-1:1997+A1:1998

<u>Standard</u>	<u>Limit</u>
CISPR 11:1990 / EN 55011-1991	Group 1, Class A
IEC 61000-4-2:1995+A1998 / EN 61000-4-2:1995	4 kV CD, 8 kV AD
IEC 61000-4-3:1995 / EN 61000-4-3:1995	3 V/m, 80 - 1000 MHz
IEC 61000-4-4:1995 / EN 61000-4-4:1995	0.5 kV sig., 1 kV power
IEC 61000-4-5:1995 / EN 61000-4-5:1996	0.5 kV L-L, 1 kV L-G
IEC 61000-4-6:1996 / EN 61000-4-6:1998	3 V, 0.15 – 80 MHz
IEC 61000-4-11:1994 / EN 61000-4-11:1998	1 cycle, 100%

Safety: IEC 61010-1:1990 + A1:1992 + A2:1995 / EN 61010-1:1993 +A2:1995
CAN/CSA-C22.2 No. 1010.1-92

Supplementary Information:

The products herewith comply with the requirements of the Low Voltage Directive 73/23/EEC and the EMC Directive 89/336/EEC and carry the CE-marking accordingly.



Santa Rosa, CA, USA 17 April 2000

Greg Pfeiffer/Quality Engineering Manager

For further information, please contact your local Agilent Technologies sales office, agent or distributor.

2

Agilent E4408B Specifications and Characteristics

About This Chapter

This chapter contains specifications and characteristics for the Agilent E4408B spectrum analyzer. The distinction between specifications and characteristics is described as follows.

- Specifications describe the performance of parameters covered by the product warranty. (The temperature range is 0 °C to 55 °C, unless otherwise noted.)
- Characteristics describe product performance that is useful in the application of the product, but is not covered by the product warranty.
- Typical performance describes additional product performance information that is not covered by the product warranty. It is performance beyond specification that 80% of the units exhibit with a 95% confidence level over the temperature range 20 to 30 °C. Typical performance does not include measurement uncertainty.
- Nominal values indicate the expected performance, or describe product performance that is useful in the application of the product, but is not covered by the product warranty.

The following conditions must be met for the analyzer to meet its specifications.

- The analyzer is within the one year calibration cycle.
- If **Auto Align All** is selected:
 - After 2 hours of storage within the operating temperature range.
 - 5 minutes after the analyzer is turned on with sweep times less than 4 seconds.
 - After the front-panel amplitude reference is connected to the INPUT, and **Align Now RF** has been run, after the analyzer is turned on. And, once every 24 hours, or if ambient temperature changes more than 30 °C.
- If **Auto Align Off** is selected:
 - When the analyzer is at a constant temperature, within the operating temperature range, for a minimum of 90 minutes.
 - After the analyzer is turned on for a minimum of 90 minutes, the front panel amplitude reference has been connected to the INPUT, and **Align Now All** has been run.
 - When **Align Now All** is run:
 - Every hour

- If the ambient temperature changes more than 3 °C
- If the 10 MHz reference changes
- When **Align Now RF** is run (with the front-panel amplitude reference connected to the INPUT):
 - Every 24 hours
 - If the ambient temperature changes more than 30 °C
- If **Auto Align All but RF** is selected:
 - When the analyzer is at a constant temperature, within the operating temperature range, for a minimum of 90 minutes.
 - After the analyzer is turned on for a minimum of 90 minutes, the front panel amplitude reference has been connected to the INPUT, and **Align Now RF** has been run.
 - When **Align Now RF** is run (with the front-panel amplitude reference connected to the INPUT):
 - Every hour
 - If the ambient temperature changes more than 3 °C

Frequency

	Specifications	Supplemental Information
Frequency Range	9 kHz to 26.5 GHz	
Band		Harmonic Mixing Mode (N ^a)
0	9 kHz to 3.0 GHz	1–
1	2.85 GHz to 6.7 GHz	1–
2	6.2 GHz to 13.2 GHz	2–
3	12.8 GHz to 19.2 GHz	4–
4	18.7 GHz to 26.5 GHz	4–

- a. N is the harmonic mixing mode. For negative mixing modes (as indicated by the “–”), the desired 1st LO harmonic is higher than the tuned frequency by the 1st IF (3.9214 for the 9 kHz to 3 GHz band, 321.4 MHz for all other bands).

	Specifications	Supplemental Information
Frequency Reference		
Aging Rate	$\pm 2 \times 10^{-6}$ /year	$\pm 1.0 \times 10^{-7}$ /day, characteristic
Settability	$\pm 5 \times 10^{-7}$	
Temperature Stability	$\pm 5 \times 10^{-6}$	

	Specifications	Supplemental Information
Frequency Readout Accuracy		
(Start, Stop, Center, Marker)	$\pm((\text{frequency indication} \times \text{frequency reference error}^{\text{a}}) + 0.75\% \text{ of span} + 15\% \text{ of RBW} + 10 \text{ Hz} + 1 \text{ Hz} \times N^{\text{b}})$	

- a. Frequency reference error = (aging rate \times period of time since adjustment + settability + temperature stability).
b. N is the harmonic mixing mode.

	Specifications	Supplemental Information
Marker Frequency Counter		
Resolution	Selectable from 1 Hz to 100 kHz	
Accuracy ^a	$\pm(\text{marker frequency} \times \text{frequency reference error}^b + \text{counter resolution})^c$	

- a. Marker level to displayed noise level > 25 dB, RBW/ Span \geq 0.002, frequency offset = 0 Hz.
- b. Frequency reference error = (aging rate \times period of time since adjustment + settability + temperature stability).
- c. For firmware revisions prior to A.03.00, add 1 Hz \times N, where N is the harmonic mixing mode.

	Specifications	Supplemental Information
Frequency Span		
Range	0 Hz (zero span), 100 Hz to 26.5 GHz	
Resolution	2 Hz \times N ^a	
Accuracy	$\pm 1.0\%$ of span	

- a. N is the harmonic mixing mode.

	Specifications	Supplemental Information
Sweep Time		
Range	4 ms to 4000 s ^a	
Tracking Generator On (Option 1DN)		50 ms is the minimum sweep time
Accuracy (Span = 0 Hz)		
4 ms to 4000 s ^a	$\pm 1\%$	
Sweep Trigger ^b	Free Run, Single, Line, Video, External, Delayed, Offset ^c	
Delayed Trigger ^d		
Range	1 μ s to 400 s	
Resolution	$\frac{\text{delay in seconds}}{65000}$ rounded up to nearest μ s	

	Specifications	Supplemental Information
Accuracy	$\pm(500 \text{ ns} + (0.01\% \text{ of delay}))$	
Offset Trigger ^c		
Resolution	$\frac{\text{sweep time}}{400}$	
Range	$\pm 327 \text{ ms}$ to $\pm 323 \text{ ks}$	Where ST = sweep time $\frac{-32766 \times ST}{400}$ to $\frac{32365 \times ST}{400}$

- a. For firmware revisions prior to A.04.00, 5 ms to 2000 s.
- b. Auto align is suspended in video, external, and delayed trigger modes while waiting for a trigger event to occur.
- c. For firmware revision A.04.00 or later.
- d. Delayed trigger is available with line and external trigger.

	Specifications	Supplemental Information
Sweep (trace) Points	401	

	Specifications	Supplemental Information
Resolution Bandwidth (RBW)		
Range		
–3 dB bandwidth	1 kHz to 3 MHz, in 1-3-10 sequence, 5 MHz	
–6 dB bandwidth (EMI)	9 kHz and 120 kHz	
Accuracy		
1 kHz to 3 MHz RBW	$\pm 15\%$	
5 MHz RBW	$\pm 30\%$	
Shape		
1 kHz to 5 MHz RBW		Synchronously tuned four poles, approximately Gaussian shape
Selectivity (60 dB/3 dB bandwidth ratio)		
1 kHz to 5 MHz RBW		<15:1, characteristic

	Specifications	Supplemental Information
Video Bandwidth (VBW) (-3 dB)		
Range	30 Hz to 1 MHz in 1-3-10 sequence	3 MHz, characteristic
Accuracy		±30%, characteristic
Shape		Post detection, single pole low-pass filter used to average displayed noise

	Specifications	Supplemental Information
Stability		
Noise Sidebands (Offset from CW signal with 1 kHz RBW, 30 Hz VBW and sample detector)		
≥10 kHz	≤ -90 dBc/Hz ^a	≤ -94 dBc/Hz ^a , typical
≥20 kHz	≤ -100 dBc/Hz ^a	≤ -105 dBc/Hz ^a , typical
≥30 kHz	≤ -106 dBc/Hz ^a	≤ -112 dBc/Hz ^a , typical
≥100 kHz	≤ -119 dBc/Hz ^a	≤ -122 dBc/Hz ^a , typical
Residual FM		
1 kHz RBW, 1 kHz VBW	≤150 Hz × N p-p in 100 ms	
System-Related Sidebands, offset from CW signal		
≥30 kHz	≤ -65 dBc ^a	

a. Add 20 Log(N) for frequencies > 6.7 GHz

Noise Sidebands Normalized to 1 Hz Versus Offset from Carrier

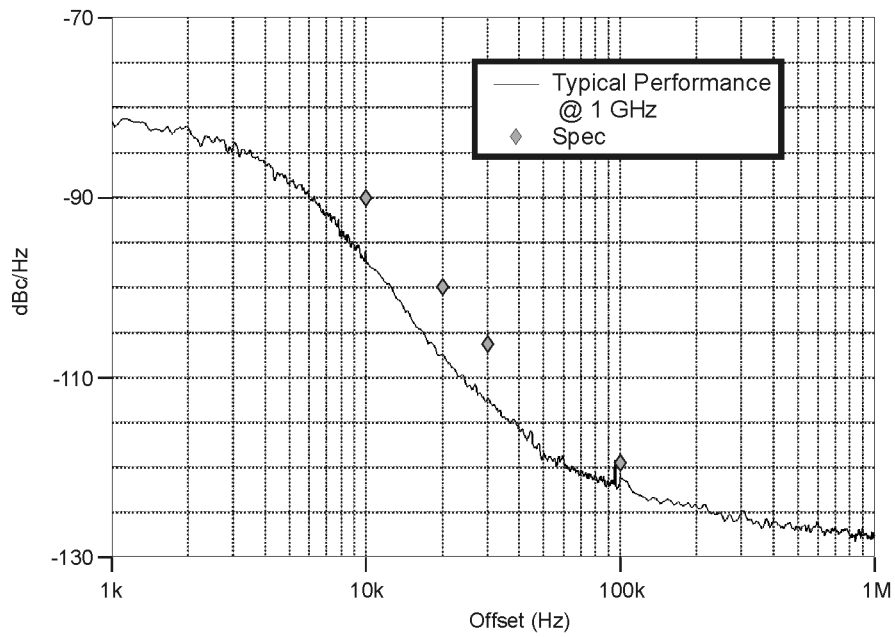

w176b

Amplitude

Amplitude specifications do not apply for the negative peak detector mode.

	Specifications	Supplemental Information
Measurement Range	Displayed Average Noise Level to Maximum Safe Input Level	
Input Attenuator Range	0 to 65 dB, in 5 dB steps	

	Specifications	Supplemental Information
Maximum Safe Input Level		
Average Continuous Power (Input attenuator setting ≥ 5 dB)	+30 dBm (1 W)	
Peak Pulse Power (for <10 μ sec pulse width, $<1\%$ duty cycle, and input attenuation ≥ 30 dB)	+50 dBm (100 W)	
dc	0 Vdc	

	Specifications	Supplemental Information
1 dB Gain Compression		
Total power at input mixer ^{ab}		
50 MHz to 3.0 GHz	0 dBm	
3.0 GHz to 6.7 GHz	0 dBm	
6.7 GHz to 13.2 GHz	-3 dBm	
13.2 GHz to 26.5 GHz	-5 dBm	

- a. Mixer power level (dBm) = input power (dBm) – input attenuation (dB).
b. For resolution bandwidths 1 kHz to 30 kHz, the maximum input signal amplitude must be \leq reference level +10 dB.

	Specifications	Supplemental Information
<p>Displayed Average Noise Level</p> <p>(Input terminated, 0 dB attenuation, sample detector, Reference Level = -70 dBm)</p> <p>1 MHz to 10 MHz</p> <p>10 MHz to 1.0 GHz</p> <p>1.0 GHz to 2.0 GHz</p> <p>2.0 GHz to 3.0 GHz</p> <p>3.0 GHz to 6.0 GHz</p> <p>6.0 GHz to 12 GHz</p> <p>12 GHz to 22 GHz</p> <p>22 GHz to 26.5 GHz</p>	<p>1 kHz RBW, 30 Hz VBW</p> <p>≤ -116 dBm</p> <p>≤ -115 dBm</p> <p>≤ -112 dBm</p> <p>≤ -112 dBm</p> <p>≤ -110 dBm</p> <p>≤ -107 dBm</p> <p>≤ -101 dBm</p>	<p>1 kHz RBW, 30 Hz VBW</p> <p>≤ -116 dBm, characteristic</p>

	Specifications	Supplemental Information
<p>Display Range</p> <p>Log Scale</p> <p>Linear Scale</p> <p>Scale Units</p>	<p>Ten divisions displayed; 0.1, 0.2, 0.5 dB/division and 1 to 20 dB/division in 1 dB steps</p> <p>Calibrated 0 to -85 dB from Reference Level</p> <p>Ten divisions</p> <p>dBm, dBmV, dBμV, V, and W</p>	

	Specifications	Supplemental Information
<p>Marker Readout Resolution</p> <p>Log scale</p> <p>0 to -85 dB from ref level</p> <p>Linear scale</p>	<p>0.04 dB</p> <p>0.01% of Reference Level</p>	

	Specifications	Supplemental Information
Frequency Response		
Absolute ^a /Relative		
10 dB attenuation		
9 kHz to 3.0 GHz		
20 to 30 °C	±0.5 dB	
0 to 55 °C	±1.0 dB	
Preselector centered for frequency >3.0 GHz		
10 dB attenuation		
3.0 GHz to 6.7 GHz		
Absolute ^a		
20 to 30 °C	±1.5 dB	
0 to 55 °C	±2.5 dB	
Relative		
20 to 30 °C	±1.3 dB	
0 to 55 °C	±1.5 dB	
6.7 GHz to 13.2 GHz		
Absolute ^a		
20 to 30 °C	±2.0 dB	
0 to 55 °C	±3.0 dB	
Relative		
20 to 30 °C	±1.8 dB	
0 to 55 °C	±2.0 dB	
13.2 GHz to 26.5 GHz		
Absolute ^a		
20 to 30 °C	±2.0 dB	
0 to 55 °C	±3.0 dB	
Relative		
20 to 30 °C	±1.8 dB	
0 to 55 °C	±2.0 dB	

a. Absolute flatness values are referenced to the amplitude at 50 MHz.

	Specifications	Supplemental Information
Input Attenuation Switching Uncertainty at 50 MHz		
Attenuator Setting		
0 dB to 5 dB	±0.3 dB	
10 dB	Reference	
15 dB	±0.3 dB	
20 to 65 dB attenuation	±(0.1 dB + 0.01 × Attenuator Setting)	

Attenuation Accuracy Relative to the 10 dB Attenuator Setting, Characteristic					
Attenuation	Frequency Range				
	dc–3 GHz	3.0–13.2 GHz	13.2–19 GHz	19–22 GHz	22–26.5 GHz
0 dB	±0.3 dB	±0.5 dB	±0.8 dB	±0.9 dB	±1.0 dB
5 dB	±0.3 dB	±0.5 dB	±0.8 dB	±0.9 dB	±1.0 dB
10 dB	Reference	Reference	Reference	Reference	Reference
15 dB	±0.4 dB	±0.5 dB	±0.8 dB	±1.0 dB	±1.5 dB
20 dB	±0.4 dB	±0.5 dB	±0.8 dB	±1.0 dB	±1.5 dB
25 dB	±0.5 dB	±0.6 dB	±0.8 dB	±1.2 dB	±2.0 dB
30 dB	±0.5 dB	±0.6 dB	±0.8 dB	±1.2 dB	±2.0 dB
35 dB	±0.6 dB	±0.7 dB	±1.0 dB	±1.8 dB	±3.0 dB
40 dB	±0.6 dB	±0.7 dB	±1.0 dB	±1.8 dB	±3.0 dB
45 dB	±0.7 dB	±1.0 dB	±1.3 dB	±2.2 dB	±3.4 dB
50 dB	±0.7 dB	±1.0 dB	±1.3 dB	±2.2 dB	±3.4 dB
55 dB	±0.9 dB	±1.1 dB	±1.6 dB	±2.7 dB	±3.5 dB
60 dB	±0.9 dB	±1.1 dB	±1.6 dB	±2.7 dB	±3.5 dB
65 dB	±1.0 dB	±1.6 dB	±2.0 dB	±3.2 dB	±3.8 dB

	Specifications	Supplemental Information
Absolute Amplitude Accuracy		
At reference settings ^a	±0.4 dB	
Overall Amplitude Accuracy ^b		
20 to 30 °C	± (0.6 dB + Absolute Frequency Response)	

- a. Settings are: reference level -20 dBm; input attenuation 10 dB; center frequency 50 MHz; RBW 1 kHz; VBW 1 kHz; scale linear or log; span 2 kHz; sweep time coupled, signal at reference level.
- b. For reference level 0 to -50 dBm; input attenuation 10 dB; RBW 1 kHz; VBW 1 kHz; scale log, log range 0 to -50 dB from reference level; sweep time coupled; signal input 0 to -50 dBm; span ≤20 kHz.

	Specifications	Supplemental Information
RF Input VSWR (at tuned frequency)		
Attenuator setting 0 dB		
9 kHz to 26.5 GHz		≤3.0:1, characteristic
Attenuator setting 5 dB		
9 kHz to 100 kHz		≤2.0:1, characteristic
100 kHz to 6.7 GHz		≤1.4:1, characteristic
6.7 GHz to 13.2 GHz		≤1.7:1, characteristic
13.2 GHz to 22.0 GHz		≤2.3:1, characteristic
22.0 GHz to 26.5 GHz		≤2.6:1, characteristic
Attenuator setting 10 to 65 dB		
9 kHz to 6.7 GHz		≤1.3:1, characteristic
6.7 GHz to 13.2 GHz		≤1.5:1, characteristic
13.2 GHz to 22.0 GHz		≤2.0:1, characteristic
22.0 GHz to 26.5 GHz		≤2.2:1, characteristic

	Specifications	Supplemental Information
Auto Alignment^a		
Sweep-to-sweep variation		±0.1 dB, characteristic

a. Set Auto Align to Off and use Align Now, All to eliminate this variation.

	Specifications	Supplemental Information
Resolution Bandwidth Switching Uncertainty (at Reference Level)		
1 kHz RBW	Reference	
3 kHz to 3 MHz RBW	±0.3 dB	
5 MHz RBW	±0.6 dB	

	Specifications	Supplemental Information
Reference Level		
Range	-149.9 dBm to maximum mixer level + attenuator setting	
Resolution		
Log Scale	±0.1 dB	
Linear Scale	±0.12% of Reference Level	
Accuracy (at a fixed frequency, a fixed attenuator, and referenced to -30 dBm)		
Reference Level (dBm) – input attenuator setting (dB)		
-10 dBm to > -60 dBm	±0.3 dB	
-60 dBm to > -85 dBm	±0.5 dB	
-85 dBm to -90 dBm	±0.7 dB	

	Specifications	Supplemental Information
Display Scale Switching Uncertainty		
Switching between Linear and Log	±0.15 dB at Reference Level	
Log Scale Switching	No error	

	Specifications	Supplemental Information
Display Scale Fidelity		
Log Maximum Cumulative 0 to 85 dB Below reference level	$\pm(0.3 \text{ dB} + 0.01 \times \text{dB from reference level})$	
Log Incremental Accuracy 0 to 80 dB below reference level	$\pm 0.4 \text{ dB}/4 \text{ dB}$	
Linear Accuracy	$\pm 2\%$ of Reference Level	

	Specifications	Supplemental Information
Spurious Responses		
Second Harmonic Distortion		
Input Signal		
10 MHz to 500 MHz	$< -60 \text{ dBc}$ for -30 dBm signal at input mixer ^a	+30 dBm SHI (second harmonic intercept)
500 MHz to 1.5 GHz	$< -70 \text{ dBc}$ for -30 dBm signal at input mixer ^a	+40 dBm SHI
1.5 GHz to 2.0 GHz	$< -80 \text{ dBc}$ for -10 dBm signal at input mixer ^a	+70 dBm SHI
2.0 GHz to 3.35 GHz	$< -95 \text{ dBc}^b$ for -10 dBm signal at input mixer ^a	+85 dBm SHI
3.35 GHz to 6.6 GHz	$< -95 \text{ dBc}^b$ for -10 dBm signal at input mixer ^a	+85 dBm SHI
6.6 GHz to 13.25 GHz	$< -95 \text{ dBc}^b$ for -10 dBm signal at input mixer ^a	+85 dBm SHI
Third Order Intermodulation Distortion		
10 MHz to 100 MHz		+5 dBm TOI (third order intercept), characteristic
100 MHz to 3 GHz	$< -75 \text{ dBc}$ for two -30 dBm signals at input mixer ^a and $>50 \text{ kHz}$ separation	+7.5 dBm TOI
3.0 GHz to 6.7 GHz	$< -75 \text{ dBc}$ for two -30 dBm signals at input mixer ^a and $>50 \text{ kHz}$ separation	+7.5 dBm TOI

	Specifications	Supplemental Information
6.7 GHz to 13.2 GHz	< -70 dBc for two -30 dBm signals at input mixer ^a and >50 kHz separation	+5.0 dBm TOI
13.2 GHz to 26.5 GHz	< -70 dBc for two -30 dBm signals at input mixer ^a and >50 kHz separation	+5.0 dBm TOI
Other Input Related Spurious		
Inband Responses		
>30 kHz offset	< -65 dBc for -20 dBm signal at input mixer ^a	
Out-of-band Responses	< -80 dBc for -10 dBm signal at input mixer ^a	

a. Mixer power level (dBm) = input power (dBm – input attenuation (dB))

b. or signal below displayed average noise level.

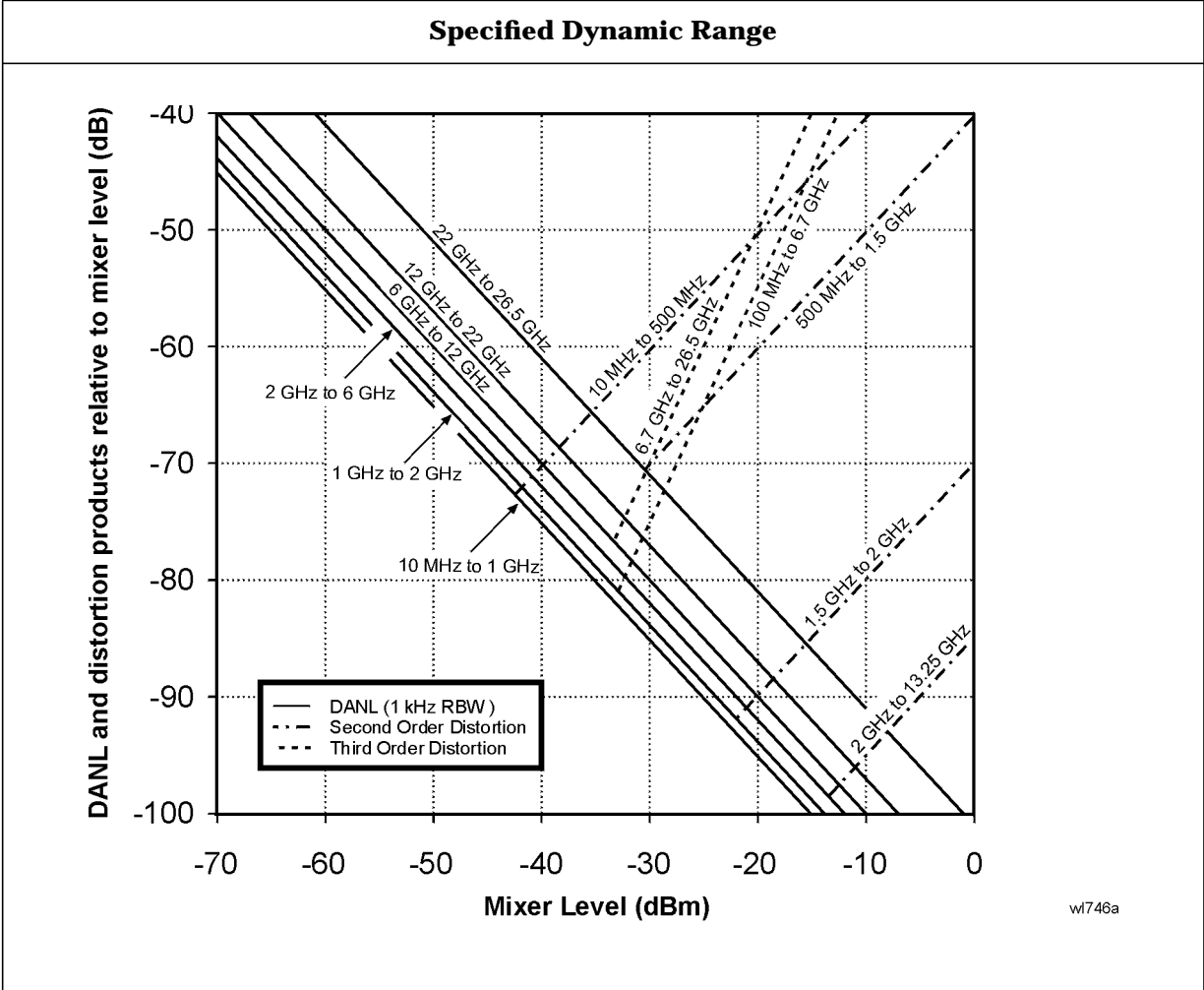

	Specifications	Supplemental Information
<p>Residual Responses (Input terminated and 0 dB attenuation)</p> <p>150 kHz to 6.7 GHz</p>	<p>< -90 dBm</p>	

Options

Tracking Generator (Option 1DN)

The spectrum analyzer/tracking generator combination will meet its specification after a cable (8120-5148) and adapter are connected between RF OUT and INPUT and **Align Now**, **TG** has been run.

	Specifications	Supplemental Information
Warmup	5 minutes	

	Specifications	Supplemental Information
Output Frequency Range	9 kHz to 3.0 GHz	

	Specifications	Supplemental Information
Output Power Level		
Range	-2 to -66 dBm	
Resolution	0.1 dB	
Absolute Accuracy (at 50 MHz with coupled source attenuator, referenced to -20 dBm)	± 0.75 dB	
Vernier		
Range	8 dB	
Accuracy (with coupled source attenuator, 50 MHz, -20 dBm)		
Incremental	± 0.2 dB/dB	
Cumulative	± 0.5 dB, total	
Output Attenuator Range	0 to 56 dB in 8 dB steps	

	Specifications	Supplemental Information
Maximum Safe Reverse Level		+30 dBm (1 W), 50 Vdc, characteristic

	Specifications	Supplemental Information
Output Power Sweep		
Range	(-10 to -2 dBm) – (Source Attenuator Setting)	
Resolution	0.1 dB	
Accuracy (zero span)	<1 dB peak-to-peak	

	Specifications	Supplemental Information
Output Flatness		
Referenced to 50 MHz, -20 dBm		
9 kHz to 10 MHz	±3 dB	
10 MHz to 3 GHz	±2 dB	

	Specifications	Supplemental Information
Spurious Outputs		
(-2 dBm output)		
Harmonic Spurs		
TG Output 9 kHz to 20 kHz	≤ -15 dBc	
TG Output 20 kHz to 3 GHz	≤ -25 dBc	
Non-harmonic Spurs		
TG Output 9 kHz to 2 GHz	≤ -27 dBc	
TG Output 2 GHz to 3 GHz	≤ -23 dBc	
LO Feedthrough		
LO Frequency 3.921409 GHz to 6.9214 GHz	≤ -16 dBm	

	Specifications	Supplemental Information
Dynamic Range	Maximum Output Power Level – Displayed Average Noise Level	

	Specifications	Supplemental Information
Output Tracking		
Drift		1.5 kHz/5 minute, characteristic
Swept Tracking Error		Usable in 1 kHz RBW after 5 minutes of warmup

	Specifications	Supplemental Information
RF Power-Off Residuals		
9 kHz to 3 GHz		< -120 dBm, characteristic

	Specifications	Supplemental Information
Output Attenuator Repeatability		
9 kHz to 300 MHz		±0.1 dB, characteristic
300 MHz to 2 GHz		±0.2 dB, characteristic
2 GHz to 3 GHz		±0.3 dB, characteristic

	Specifications	Supplemental Information
Output VSWR		
0 dB attenuation		<2.0:1, characteristic
≥ 8 dB attenuation		<1.5:1, characteristic

	Specifications	Supplemental Information
Output Attenuator Accuracy		
0 dB	Reference	±0.5 dB, characteristic
8 dB		±0.5 dB, characteristic
16 dB		
24 dB		±0.5 dB, characteristic
32 dB		±0.6 dB, characteristic
40 dB		±0.8 dB, characteristic
48 dB		±1.0 dB, characteristic
56 dB		±1.1 dB, characteristic

Tracking Generator Output Accuracy
Relative Accuracy (Referred to -20 dBm) = Output Attenuator Accuracy + Vernier Accuracy + Output Flatness
Absolute Accuracy = Relative Accuracy (Referred to -20 dBm) + Absolute Accuracy at 50 MHz

General

	Specifications	Supplemental Information
Temperature Range		
Operating	0 to 55 °C	Floppy disk 10 to 40 °C
Storage	-40 to 75 °C	

	Specifications	Supplemental Information
Audible Noise (ISO 7779)		
Sound Pressure at 25 °C		<40 dBa, (<4.6 Bels power)

	Specifications	Supplemental Information
Military Specification	Has been type tested to the environmental specifications of MIL-PRF-28800F class 3.	

	Specifications	Supplemental Information
EMI Compatibility	Conducted and radiated emission is in compliance with CISPR Pub. 11/1990 Group 1 Class A.	

	Specifications	Supplemental Information
Immunity Testing		
Radiated Immunity		Testing was done at 3 V/m according to IEC 801-3/1984. When the analyzer tuned frequency is identical to the immunity test signal frequency, there may be signals of up to -60 dBm displayed on the screen.
Electrostatic Discharge		Air discharges of up to 8 kV were applied according to IEC 801-2/1991. Discharges to center pins of any of the connectors may cause damage to the associated circuitry.

	Specifications	Supplemental Information
Power Requirements		
ac Operation		
Voltage, frequency	90 to 132 Vrms, 47 to 440 Hz 195 to 250 Vrms, 47 to 66 Hz	
Power Consumption, On	<300 W	
Power Consumption, Standby	<5 W	
dc Operation		
Voltage	12 to 20 Vdc	
Power Consumption	<200 W	

	Specifications	Supplemental Information
Measurement Speed		
Local Measurement and Display Update rate ^a		≥ 28/s, characteristic
Remote Measurement and GPIB Transfer Rate ^{b,c} (Option A4H)		≥ 28/s, characteristic
RF Center Frequency Tune, Measure, and GPIB Transfer Time ^{b,d} (Option A4H)		≤ 90 ms, characteristic

- Factory preset, auto align Off, fixed center frequency, RBW = 1 MHz, spans >10 MHz and ≤600 MHz, and stop frequency ≤3 GHz.
- Display Off (:DISPlay:ENABle OFF), and 32-bit integer data format (:FORMat:DATA INT,32), if Option A4J is installed, disable sweep ramp, (:SYSTem:PORTs:IFVSweep:ENABle OFF), markers Off, single sweep, measured with IBM compatible PC with 550 MHz Pentium® III running Windows® NT 4.0, one meter GPIB cable, National Instruments PCI-GPIB card and NI-488.2 DLL
- Factory preset, auto align Off, fixed center frequency, RBW = 1 MHz, and span = 20 MHz, stop frequency ≤3 GHz, average of 100 measurements.
- Factory preset, auto align Off, RBW = 1 MHz, span= 20 MHz, stop frequency ≤3 GHz, center frequency tune step size = 50 MHz.

	Specifications	Supplemental Information
Data Storage		
Internal		200 Traces or States
External (10 to 40 °C) 3.5" 1.44 MB, MS-DOS® compatible floppy disk		200 Traces or States

	Specifications	Supplemental Information
Demod Tune and Listen Demod <i>(Option A4J)</i>	AM	Internal speaker, front-panel earphone jack and front-panel volume control. An uncalibrated demodulated signal is available on the AUX VIDEO OUT connector at the rear panel.

	Specifications	Supplemental Information
Weight (without options) Net Shipping		17.1 kg (37.7 lb), characteristic 31.9 kg (70.3 lb), characteristic

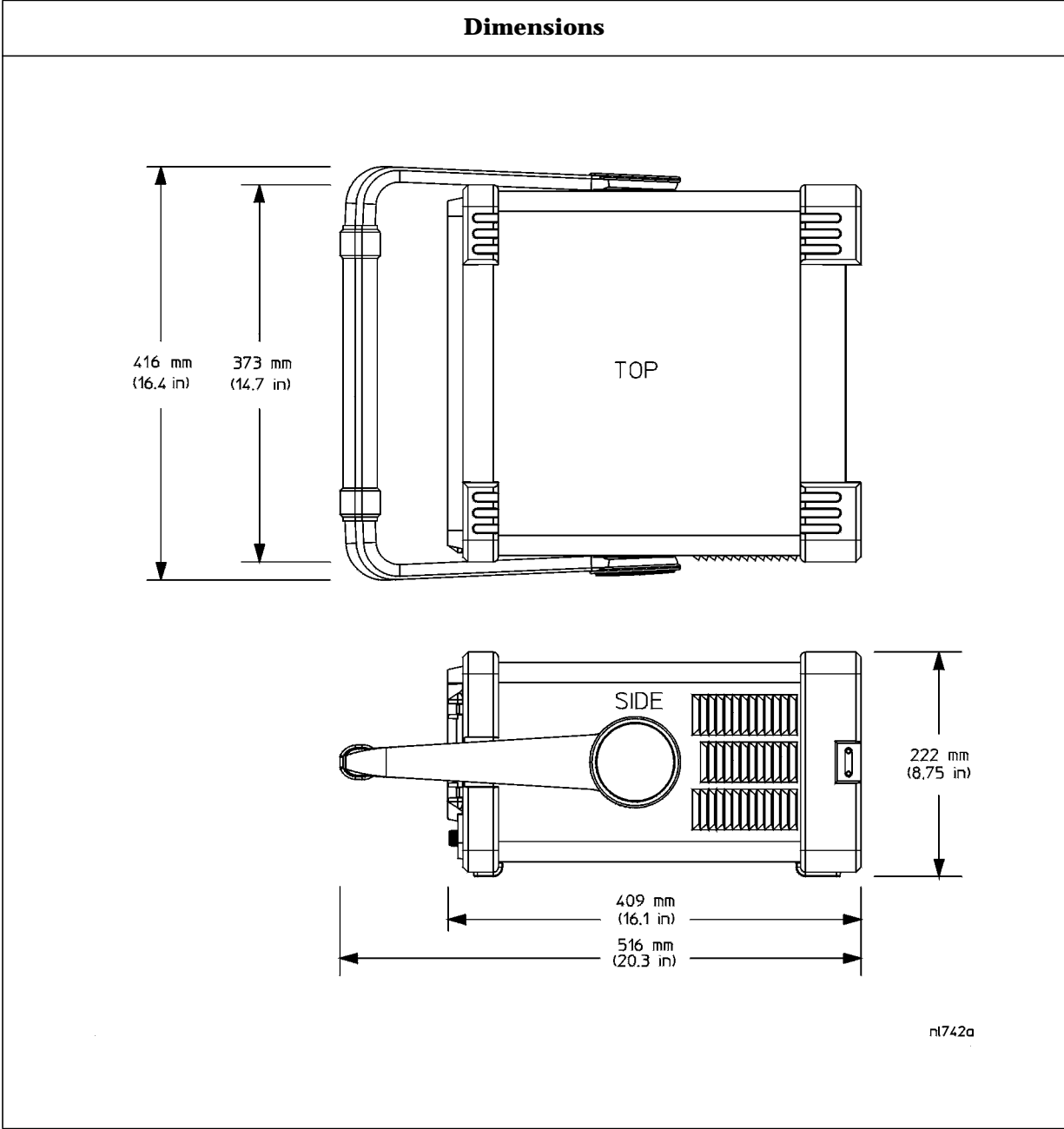

Inputs and Outputs

Front Panel

	Specifications	Supplemental Information
INPUT 50 Ω		
Connector <i>(Option BAB)</i>	Type-N female APC 3.5 male	
Impedance		50 Ω , nominal

	Specifications	Supplemental Information
RF OUT 50 Ω, (Option 1DN)		
Connector	Type-N female	
Impedance		50 Ω , nominal

	Specifications	Supplemental Information
AMPTD REF OUT^a		Amplitude Reference
Connector	BNC female	
Impedance		50 Ω , nominal
Frequency		50 MHz
Frequency Accuracy		Frequency reference error ^b
50 Ω Amplitude ^c		-20 dBm, nominal

- Turn the amplitude reference on/off by pressing the keys: **Input/Output, Amptd Ref Out**.
- Frequency reference error = (aging rate \times period of time since adjustment + settability + temperature stability).
- The internal amplitude reference actual power is stored internally.

	Specifications	Supplemental Information
PROBE POWER		
Voltage/Current		+15 Vdc, $\pm 7\%$ at 150 mA max., characteristic -12.6 Vdc $\pm 10\%$ at 150 mA max., characteristic

	Specifications	Supplemental Information
EXT KEYBOARD^a		Used for entering screen titles and filenames only. Interface compatible with most IBM-compatible PC keyboards.
Connector	6-pin mini-DIN	

a. The feature is not implemented in firmware revisions prior to A.04.00.

	Specifications	Supplemental Information
Speaker		Front panel knob controls volume

	Specifications	Supplemental Information
Headphone		Front panel knob controls volume
Connector	3.5 mm (1/8 inch) miniature audio jack	
Power Output		0.2 W into 4 Ω , characteristic

Rear Panel

	Specifications	Supplemental Information
10 MHz REF OUT		
Connector	BNC female	
Impedance		50 Ω , nominal
Output Amplitude		>0 dBm, characteristic

	Specifications	Supplemental Information
10 MHz REF IN		
Connector	BNC female	Note: Analyzer noise sidebands and spurious response performance may be affected by the quality of the external reference used.
Impedance		50 Ω , nominal
Input Amplitude Range		-15 to +10 dBm, characteristic
Frequency		10 MHz, nominal

	Specifications	Supplemental Information
GATE TRIG/EXT TRIG IN		
Connector	BNC female	
External Trigger Input		
Trigger Level		Selectable positive or negative edge initiates sweep in EXT TRIG mode (5 V TTL)

	Specifications	Supplemental Information
GATE/HI SWP OUT		
Connector	BNC female	
High Sweep Output		
Level		High = sweep ^a ; Low = retrace (5 V TTL)

a. High sweep may be high longer than the indicated sweep times.

	Specifications	Supplemental Information
VGA OUTPUT		
Connector	VGA compatible, 15-pin mini D-SUB	
Format		VGA (31.5 kHz horizontal, 60 Hz vertical sync rates, non-interlaced) Analog RGB
Resolution	640 \times 480	

	Specifications	Supplemental Information
AUX IF OUT <i>(Option A4J)</i>		
Connector	BNC female	
Frequency		21.4 MHz, nominal
Amplitude (for signal at reference level and for reference levels – input attenuation of –10 to –70 dBm)		–10 dBm (uncorrected), characteristic
Impedance		50 Ω , nominal

	Specifications	Supplemental Information
AUX VIDEO OUT <i>(Option A4J)</i>		
Connector	BNC female	
Amplitude Range (into >10 k Ω)		0 to 1 V (uncorrected), characteristic

	Specifications	Supplemental Information
HI SWP IN <i>(Option A4J)</i>		
Connector	BNC female	
Input		Open collector, low resets and holds the sweep (5 V TTL)

	Specifications	Supplemental Information
HI SWP OUT <i>(Option A4J)</i>		
Connector	BNC female	
Output		High = sweep ^a , Low = retrace (5 V TTL)

a. High sweep may be high longer than the indicated sweep times.

	Specifications	Supplemental Information
SWP OUT <i>(Option A4J)</i>		
Connector	BNC female	
Amplitude		0 to +10 V ramp, characteristic

	Specifications	Supplemental Information
PRESEL TUNE OUTPUT		
Connector	BNC female	
Load Impedance (dc coupled)		> 10 k Ω , nominal
Range		0 to +10 V, characteristic
Sensitivity		0.33 V/GHz of tuned frequency > 3 GHz, characteristic

	Specifications	Supplemental Information
GPIB Interface <i>(Option A4H)</i>		
Connector	IEEE-488 bus connector	
GPIB Codes		SH1, AH1, T6, SR1, RL1, PP0, DC1, C1, C2, C3 and C28

	Specifications	Supplemental Information
Serial Interface <i>(Option 1AX)</i>		
Connector	9-pin D-SUB male	RS-232

	Specifications	Supplemental Information
Parallel Interface <i>(Option A4H or 1AX)</i>		Printer port only
Connector	25-pin D-SUB female	

Regulatory Information

CAUTION This product is designed for use in Installation Category II and Pollution Degree 2 per IEC 1010 and 664 respectively.

NOTE This product has been designed and tested in accordance with IEC Publication 1010, Safety Requirements for Electronic Measuring Apparatus, and has been supplied in a safe condition. The instruction documentation contains information and warnings which must be followed by the user to ensure safe operation and to maintain the product in a safe condition.



The CE mark is a registered trademark of the European Community (if accompanied by a year, it is the year when the design was proven).



The CSA mark is the Canadian Standards Association safety mark.

ISM 1-A

This is a symbol of an Industrial Scientific and Medical Group 1 Class A product. (CISPR 11, Clause 4)

Declaration of Conformity

DECLARATION OF CONFORMITY

According to ISO/IEC Guide 22 and CEN/CENELEC EN 45014

Manufacturer's Name: Agilent Technologies, Inc.

Manufacturer's Address: 1400 Fountaingrove Parkway
Santa Rosa, CA 95403-1799
USA

Declares that the products

Product Name: Spectrum Analyzer

Model Number: E4401B, E4402B, E4403B, E4404B,
E4405B, E4407B, E4408B, E4411B

Product Options: This declaration covers all options of the above products.

Conform to the following product specifications:

EMC: IEC 61326-1:1997+A1:1998 / EN 61326-1:1997+A1:1998

<u>Standard</u>	<u>Limit</u>
CISPR 11:1990 / EN 55011-1991	Group 1, Class A
IEC 61000-4-2:1995+A1998 / EN 61000-4-2:1995	4 kV CD, 8 kV AD
IEC 61000-4-3:1995 / EN 61000-4-3:1995	3 V/m, 80 - 1000 MHz
IEC 61000-4-4:1995 / EN 61000-4-4:1995	0.5 kV sig., 1 kV power
IEC 61000-4-5:1995 / EN 61000-4-5:1996	0.5 kV L-L, 1 kV L-G
IEC 61000-4-6:1996 / EN 61000-4-6:1998	3 V, 0.15 - 80 MHz
IEC 61000-4-11:1994 / EN 61000-4-11:1998	1 cycle, 100%

Safety: IEC 61010-1:1990 + A1:1992 + A2:1995 / EN 61010-1:1993 +A2:1995
CAN/CSA-C22.2 No. 1010.1-92

Supplementary Information:

The products herewith comply with the requirements of the Low Voltage Directive 73/23/EEC and the EMC Directive 89/336/EEC and carry the CE-marking accordingly.



Santa Rosa, CA, USA 17 April 2000

Greg Pfeiffer/Quality Engineering Manager

For further information, please contact your local Agilent Technologies sales office, agent or distributor.

3

**Agilent E4411B Specifications and
Characteristics**

About This Chapter

This chapter contains specifications and characteristics for the Agilent E4411B spectrum analyzer. The distinction between specifications and characteristics is described as follows.

- Specifications describe the performance of parameters covered by the product warranty. (The temperature range is 0 °C to 55 °C, unless otherwise noted.)
- Characteristics describe product performance that is useful in the application of the product, but is not covered by the product warranty.
- Typical performance describes additional product performance information that is not covered by the product warranty. It is performance beyond specification that 80% of the units exhibit with a 95% confidence level over the temperature range 20 to 30 °C. Typical performance does not include measurement uncertainty.
- Nominal values indicate the expected performance, or describe product performance that is useful in the application of the product, but is not covered by the product warranty.

The following conditions must be met for the analyzer to meet its specifications.

- The analyzer is within the one year calibration cycle.
- If **Auto Align All** is selected:
 - After 2 hours of storage within the operating temperature range.
 - 5 minutes after the analyzer is turned on with sweep times less than 4 seconds.
- If **Auto Align Off** is selected:
 - When the analyzer is at a constant temperature, within the operating temperature range, for a minimum of 90 minutes.
 - After the analyzer is turned on for a minimum of 90 minutes and **Align Now All** has been run.
 - When **Align Now All** is run:
 - Every hour
 - If the ambient temperature changes more than 3 °C
 - If the 10 MHz reference changes

- ❑ If **Auto Align All but RF** is selected:
 - When the analyzer is at a constant temperature, within the operating temperature range, for a minimum of 90 minutes.
 - After the analyzer is turned on for a minimum of 90 minutes and **Align Now RF** has been run.
 - When **Align Now RF** is run:
 - Every hour
 - If the ambient temperature changes more than 3 °C

Frequency

	Specifications	Supplemental Information
Frequency Range		
50 Ω	9 kHz to 1.5 GHz	
75 Ω (<i>Option 1DP</i>)	1 MHz to 1.5 GHz	

	Specifications	Supplemental Information
Frequency Reference		
Aging Rate	$\pm 2 \times 10^{-6}$ /year	$\pm 1.0 \times 10^{-7}$ /day, characteristic
Settability	$\pm 5 \times 10^{-7}$	
Temperature Stability	$\pm 5 \times 10^{-6}$	

	Specifications	Supplemental Information
Frequency Readout Accuracy		
(Start, Stop, Center, Marker)	\pm ((frequency indication \times frequency reference error ^a) + 0.75% of span + 15% of RBW + 10 Hz)	

a. Frequency reference error = (aging rate \times period of time since adjustment + settability + temperature stability).

	Specifications	Supplemental Information
Marker Frequency Counter		
Resolution	Selectable from 1 Hz to 100 kHz	
Accuracy ^a	\pm (marker frequency \times frequency reference error ^b + counter resolution)	

a. Marker level to displayed noise level > 25 dB, RBW/ Span \geq 0.002, frequency offset = 0 Hz.

b. Frequency reference error = (aging rate \times period of time since adjustment + settability + temperature stability).

	Specifications	Supplemental Information
Frequency Span		
Range	0 Hz (zero span), 100 Hz to 1.5 GHz	
Resolution	2 Hz	
Accuracy	±1.0% of span	

	Specifications	Supplemental Information
Sweep Time		
Range	4 ms to 4000 s ^a	
Tracking Generator On (Option 1DN or 1DQ)		50 ms is the minimum sweep time
Accuracy (Span = 0 Hz)		
4 ms to 4000 s ^a	±1%	
Sweep Trigger ^b	Free Run, Single, Line, Video, External, Delayed, Offset ^c	
Delayed Trigger ^d		
Range	1 μs to 400 s	
Resolution	$\frac{\text{delay in seconds}}{65000}$ rounded up to nearest μs	
Accuracy	±(500 ns + (0.01% of delay))	
Offset Trigger ^c		
Resolution	$\frac{\text{sweep time}}{400}$	
Range	±327 ms to ±323 ks	Where ST = sweep time $\frac{-32766 \times ST}{400}$ to $\frac{32365 \times ST}{400}$

- a. For firmware revisions prior to A.04.00, 5 ms to 2000 s.
- b. Auto align is suspended in video, external, and delayed trigger modes while waiting for a trigger event to occur.
- c. For firmware revision A.04.00 or later.
- d. Delayed trigger is available with line and external trigger.

	Specifications	Supplemental Information
Sweep (trace) Points	401	

	Specifications	Supplemental Information
Resolution Bandwidth (RBW)		
Range		
–3 dB bandwidth	1 kHz to 3 MHz, in 1-3-10 sequence, 5 MHz	
–6 dB bandwidth (EMI)	9 kHz and 120 kHz	
Accuracy		
1 kHz to 3 MHz RBW	±15%	
5 MHz RBW	±30%	
Shape		
1 kHz to 5 MHz RBW		Synchronously tuned four poles, approximately Gaussian shape
Selectivity (60 dB/3 dB bandwidth ratio)		
1 kHz to 5 MHz RBW		<15:1, characteristic

	Specifications	Supplemental Information
Video Bandwidth (VBW) (–3 dB)		
Range	30 Hz to 1 MHz in 1-3-10 sequence	3 MHz, characteristic
Accuracy		±30%, characteristic
Shape		Post detection, single pole low-pass filter used to average displayed noise

	Specifications	Supplemental Information
Stability		
Noise Sidebands (Offset from CW signal with 1 kHz RBW, 30 Hz VBW and sample detector)		
≥10 kHz	≤ -93 dBc/Hz	≤ -95 dBc/Hz, typical
≥20 kHz	≤ -100 dBc/Hz	≤ -102 dBc/Hz, typical
≥30 kHz	≤ -104 dBc/Hz	≤ -106 dBc/Hz, typical
≥100 kHz	≤ -113 dBc/Hz	≤ -116 dBc/Hz, typical
Residual FM		
1 kHz RBW, 1 kHz VBW	≤150 Hz p-p in 100 ms	
System-Related Sidebands, offset from CW signal		
≥30 kHz	≤ -65 dBc	

Noise Sidebands Normalized to 1 Hz Versus Offset from Carrier

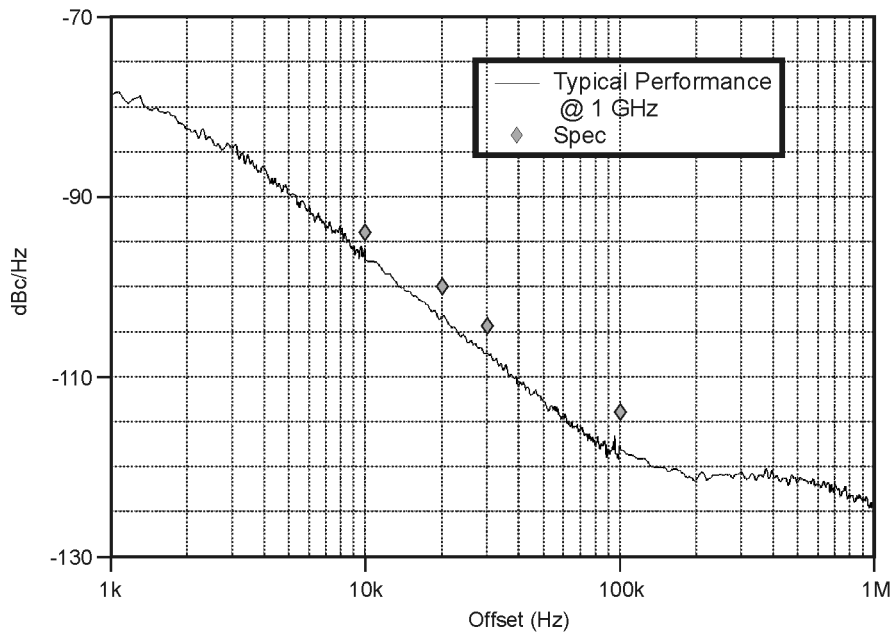

w175b

Amplitude

Amplitude specifications do not apply for the negative peak detector mode.

	Specifications	Supplemental Information
Measurement Range	Displayed Average Noise Level to Maximum Safe Input Level	
Input Attenuator Range	0 to 60 dB, in 5 dB steps	

	Specifications	Supplemental Information
Maximum Safe Input Level		
Input attenuator setting ≥ 15 dB		Signals $> +33$ dBm (2 W) or $+79$ dBmV (1 W) (<i>Option 1DP</i>) nominal may trigger input protection, which disconnects the input path.
Average Continuous Power or Peak Pulse Power		
50 Ω	+30 dBm (1 W)	
75 Ω (<i>Option 1DP</i>)	+75 dBmV (0.4 W)	
dc	100 Vdc	dc transients may momentarily trigger input protection
Input attenuator setting < 15 dB		Signals $> +6$ dBm (4 mW) or $+61$ dBmV (15 mW) (<i>Option 1DP</i>) nominal may trigger input protection, which automatically increases input attenuation to 15 dB.
Average Continuous Power or Peak Pulse Power		
50 Ω	+3 dBm (2 mW)	
75 Ω (<i>Option 1DP</i>)	+59 dBmV (10 mW)	
dc	100 Vdc	dc transients may trigger input protection.

	Specifications	Supplemental Information
1 dB Gain Compression Total power at input mixer ^{ab} 50 MHz to 1.5 GHz 50 Ω 75 Ω (<i>Option 1DP</i>)	0 dBm +46.75 dBmV	

- a. Mixer power level (dBm) = input power (dBm) – input attenuation (dB).
 b. For resolution bandwidths 1 kHz to 30 kHz, the maximum input signal amplitude must be ≤ reference level +10 dB. (*Option 1DP: For resolution bandwidths 1 kHz to 30 kHz, the maximum input signal amplitude must be ≤ reference level +5 dB*).

	Specifications	Supplemental Information
Displayed Average Noise Level (Input terminated, 0 dB attenuation, sample detector, Reference Level = -70 dBm) (75 Ω: Reference Level = -21.24 dBmV)		
50 Ω 400 kHz to 10 MHz 10 MHz to 500 MHz 500 MHz to 1.0 GHz 1.0 GHz to 1.5 GHz	1 kHz RBW, 30 HzVBW ≤ -115 dBm ≤ -119 dBm ≤ -117 dBm ≤ -113 dBm	
75 Ω, (<i>Option 1DP</i>) 1 MHz to 10 MHz 10 MHz to 500 MHz 500 MHz to 1.0 GHz 1.0 GHz to 1.5 GHz	1 kHz RBW, 30 Hz VBW ≤ -63 dBmV ≤ -65 dBmV ≤ -60 dBmV ≤ -53 dBmV	

	Specifications	Supplemental Information
Display Range		
Log Scale	Ten divisions displayed; 0.1, 0.2, 0.5 dB/division and 1 to 20 dB/division in 1 dB steps Calibrated 0 to –85 dB from Reference Level	
Linear Scale	Ten divisions	
Scale Units	dBm, dBmV, dB μ V, V, and W	

	Specifications	Supplemental Information
Marker Readout Resolution		
Log scale 0 to –85 dB from ref level	0.04 dB	
Linear scale	0.01% of Reference Level	

	Specifications	Supplemental Information
Frequency Response		
50 Ω , Absolute ^a /Relative 9 kHz to 1.5 GHz 10 dB attenuation 20 to 30 °C 0 to 55 °C 0 dB, 5 dB, 15 to 60 dB attenuation	± 0.5 dB ± 1.0 dB	± 1.0 dB, characteristic
75 Ω , Absolute ^a /Relative (Option 1DP) 1 MHz to 1.5 GHz 10 dB attenuation 20 to 30 °C 0 to 55 °C 0, 5, 15 to 50 dB attenuation	± 0.5 dB ± 1.0 dB	± 1.0 dB, characteristic

	Specifications	Supplemental Information
55 to 60 dB attenuation 1 MHz to 1 GHz 1 GHz to 1.5 GHz		±1.0 dB, characteristic ±1.25 dB, characteristic

a. Absolute flatness values are referenced to the amplitude at 50 MHz.

	Specifications	Supplemental Information
Input Attenuation Switching Uncertainty at 50 MHz Attenuator Setting 0 dB to 5 dB 10 dB 15 dB 20 to 60 dB attenuation	±0.3 dB Reference ±0.3 dB $\pm(0.1 \text{ dB} + 0.01 \times \text{Attenuator Setting})$	

	Specifications	Supplemental Information
Absolute Amplitude Accuracy At reference settings ^a Overall Amplitude Accuracy ^b 20 to 30 °C	±0.4 dB $\pm (0.6 \text{ dB} + \text{Absolute Frequency Response})$	

- a. Settings are: reference level -25 dBm; (75 Ω reference level +28.75 dBmV); input attenuation 10 dB; center frequency 50 MHz; RBW 1 kHz; VBW 1 kHz; scale linear or log; span 2 kHz; sweep time coupled, signal at reference level.
- b. For reference level 0 to -50 dBm; input attenuation 10 dB; RBW 1 kHz; VBW 1 kHz; scale log, log range 0 to -50 dB from reference level; sweep time coupled; signal input 0 to -50 dBm; span ≤20 kHz.

	Specifications	Supplemental Information
RF Input VSWR (at tuned frequency) Attenuator setting 50 Ω 0 to 5 dB attenuation 10 to 60 dB attenuation 75 Ω 1 MHz to 1.1 GHz 0 to 5 dB attenuation 10 to 60 dB attenuation 1.1 GHz to 1.5 GHz 0 to 60 dB attenuation Input protection is tripped Amptd Ref is On Auto Align All is selected		≤1.55:1, characteristic ≤1.35:1, characteristic ≤1.55:1, characteristic ≤1.35:1, characteristic ≤2.0:1, characteristic Open input, characteristic Open input, characteristic Open input momentarily during retrace, characteristic

	Specifications	Supplemental Information
Auto Alignment^a Sweep-to-sweep variation		±0.1 dB, characteristic

a. Set Auto Align to Off and use Align Now, All to eliminate this variation.

	Specifications	Supplemental Information
Resolution Bandwidth Switching Uncertainty (at Reference Level) 1 kHz RBW 3 kHz to 3 MHz RBW 5 MHz RBW	Reference ±0.3 dB ±0.6 dB	

	Specifications	Supplemental Information
Reference Level		
Range	-149.9 dBm to maximum mixer level + attenuator setting	
Resolution		
Log Scale	±0.1 dB	
Linear Scale	±0.12% of Reference Level	
50 Ω, Accuracy (at a fixed frequency, a fixed attenuator, and referenced to -35 dBm)		
Reference Level (dBm) – input attenuator setting (dB)		
-10 dBm to > -60 dBm	±0.3 dB	
-60 dBm to > -85 dBm	±0.5 dB	
-85 dBm to -90 dBm	±0.7 dB	
75 Ω (<i>Option 1DP</i>), Accuracy (at a fixed frequency, a fixed attenuator, and referenced to 18.75 dBmV)		
Reference Level (dBmV) – input attenuator setting (dB)		
38.75 dBmV to > -11.25 dBmV	±0.3 dB	
-11.25 dBmV to > -26.25 dBmV	±0.5 dB	
-26.25 dBmV to -41.25 dBmV	±0.7 dB	

	Specifications	Supplemental Information
Display Scale Switching Uncertainty		
Switching between Linear and Log	±0.15 dB at Reference Level	
Log Scale Switching	No error	

	Specifications	Supplemental Information
Display Scale Fidelity		
Log Maximum Cumulative 0 to 85 dB below reference level	$\pm(0.3 \text{ dB} + 0.01 \times \text{dB from reference level})$	
Log Incremental Accuracy 0 to 80 dB below reference level	$\pm 0.4 \text{ dB/4 dB}$	
Linear Accuracy	$\pm 2\%$ of Reference Level	

	Specifications	Supplemental Information
Spurious Responses		
50 Ω		
Second Harmonic Distortion Input Signal 2 MHz to 750 MHz	$< -75 \text{ dBc}$ for -40 dBm signal at input mixer ^a	+35 dBm SHI (second harmonic intercept)
Third Order Intermodulation Distortion 2 MHz to 10 MHz		+14.5 dBm TOI (third order intercept), typical
10 MHz to 1.5 GHz	$< -75 \text{ dBc}$ for two -30 dBm signals at input mixer ^a and $>50 \text{ kHz}$ separation.	+7.5 dBm TOI
Other Input Related Spurious 30 kHz \leq offset \leq 1200 MHz	$< -65 \text{ dBc}$ for -20 dBm signals at input mixer ^a \leq 1.5 GHz.	
Offset $>$ 1200 MHz	$< -45 \text{ dBc}$ for -20 dBm signal at input mixer ^a \leq 1.5 GHz.	
Noise Floor Degradation Input frequency = 1210.7 MHz \pm RBW		$< -62 \text{ dBc}$ for -45 dBm signal at input mixer ^a

a. Mixer Power Level (dBm) = Input Power (dBm) – Input Attenuation (dB).

	Specifications	Supplemental Information
Spurious Responses		
75 Ω , (Option 1DP)		
Second Harmonic Distortion		
Input signal		
2 MHz to 750 MHz	< -75 dBc for +8.75 dBmV signal at input mixer ^a	
Third Order Intermodulation Distortion		
10 MHz to 1.5 GHz	< -75 dBc for two +18.75 dBmV signals at input mixer ^a and >50 kHz separation.	
Other Input Related Spurious		
30 kHz \leq offset	< -65 dBc for +28.75 dBmV signal at input mixer ^a	
\leq 1200 MHz	\leq 1.5 GHz.	
Offset >1200 MHz	< -45 dBc, for +28.75 dBmV signal at input mixer ^a	
	\leq 1.5 GHz.	
Noise Floor Degradation		
Input frequency =		< -62 dBc, for +3.75 dBmV signal at input mixer ^a
1210.7 MHz \pm RBW		

a. Mixer Power Level (dBmV) = Input Power (dBmV) – Input Attenuation (dB)

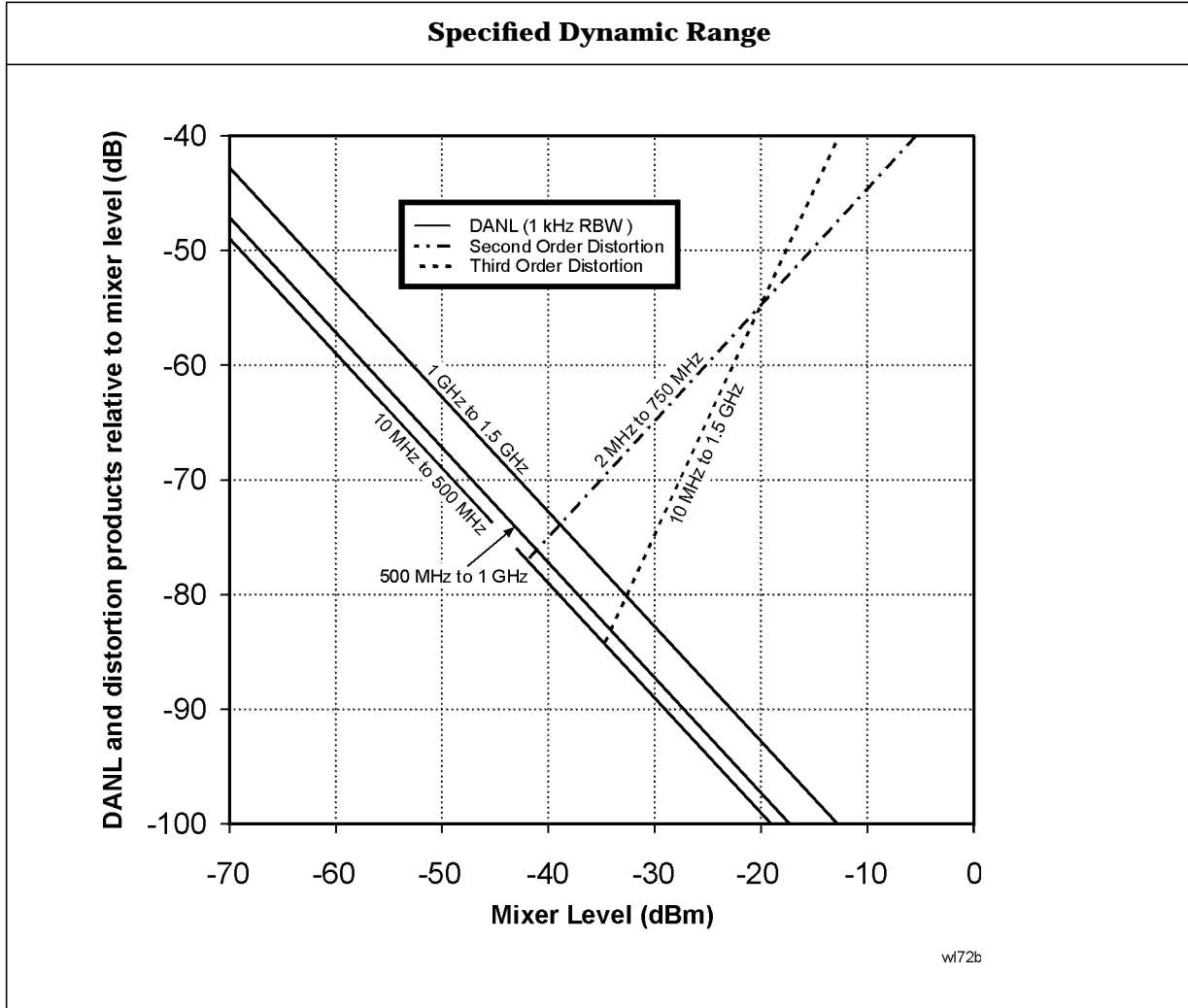

	Specifications	Supplemental Information
<p>Residual Responses (Input terminated and 0 dB attenuation)</p> <p>50 Ω</p> <p>150 kHz to 1.5 GHz</p> <p>75 Ω, (Option 1DP)</p> <p>1 MHz to 1.5 GHz</p>	<p>< -90 dBm</p> <p>< -36 dBmV</p>	

Options

Tracking Generator (Option 1DN or 1DQ)

	Specifications	Supplemental Information
Warmup	5 minutes	

	Specifications	Supplemental Information
Output Frequency Range		
50 Ω (Option 1DN)	9 kHz to 1.5 GHz	
75 Ω (Option 1DQ)	1 MHz to 1.5 GHz	

	Specifications	Supplemental Information
Output Power Level		
20 to 30 °C		
Range		
50 Ω (Option 1DN)	0 to -70 dBm	
75 Ω (Option 1DQ)	+42.75 to -27.25 dBmV	
Resolution	0.1 dB	
Absolute Accuracy (at 50 MHz with coupled source attenuator)		
50 Ω (Option 1DN) referenced to 0 dBm	± 0.5 dB	
75 Ω (Option 1DQ) referenced to +42.75 dBmV	± 1.5 dB	
Vernier		
Range	10 dB	
Accuracy (with coupled source attenuator)		
50 Ω (Option 1DN) referenced to 0 dBm	± 0.75 dB, for 0 to -10 dBm	
75 Ω (Option 1DQ) referenced to 42.75 dBmV	± 0.9 dB, for +42.75 to +32.75 dBmV	
Output Attenuator Range	0 to 60 dB in 10 dB steps	

	Specifications	Supplemental Information
Maximum Safe Reverse Level		
50 Ω (Option 1DN) ^a		+20 dBm (0.1 W), 100 Vdc, characteristic
75 Ω (Option 1DQ) ^a		+69 dBmV (0.1 W), 100 Vdc, characteristic

a. dc transients may trigger reverse power protection.

	Specifications	Supplemental Information
Output Power Sweep		
20 to 30 °C		
Range		
50 Ω (Option 1DN)	(-15 to 0 dBm) – (Source Attenuator Setting)	
75 Ω (Option 1DQ)	(27.75 to 42.75 dBmV) – (Source Attenuator Setting)	
Resolution	0.1 dB	
Accuracy (zero span)		
50 Ω (Option 1DN)	<1.5 dB peak-to-peak	
75 Ω (Option 1DQ)	<1.8 dB peak-to-peak	

	Specifications	Supplemental Information
Output Flatness		
Referenced to 50 MHz, 0 dB attenuator		
50 Ω (Option 1DN)		
9 kHz to 10 MHz	± 2 dB	
10 MHz to 1.5 GHz	± 1.5 dB	
75 Ω (Option 1DQ)		
1 MHz to 10 MHz	± 2.5 dB	
10 MHz to 1.5 GHz	± 2 dB	

	Specifications	Supplemental Information
Spurious Outputs 50 Ω (<i>Option 1DN</i>) (0 dBm output) 75 Ω (<i>Option 1DQ</i>) (+42.75 dBmV output) Harmonic Spurs 9 kHz to 20 MHz 20 MHz to 1.5 GHz Non-harmonic Spurs	 < -20 dBc < -25 dBc < -35 dBc	

	Specifications	Supplemental Information
Dynamic Range	Maximum Output Power Level – Displayed Average Noise Level	

	Specifications	Supplemental Information
Output Tracking Drift Swept Tracking Error		No error No error for coupled sweep times

	Specifications	Supplemental Information
RF Power-Off Residuals 50 Ω (<i>Option 1DN</i>) 100 kHz to 1.5 GHz 75 Ω (<i>Option 1DQ</i>) 1 MHz to 1.5 GHz		< -120 dBm, characteristic < 65 dBmV, characteristic

	Specifications	Supplemental Information
Output Attenuator Repeatability		± 0.2 dB, characteristic

	Specifications	Supplemental Information
Output VSWR 50 Ω (<i>Option 1DN</i>) 75 Ω (<i>Option 1DQ</i>)		<2.5:1, characteristic <2.0:1, characteristic

	Specifications	Supplemental Information
Output Attenuator Accuracy 0 dB 10 dB 20 dB 30 dB 40 dB 50 dB 60 dB	Reference	 ±0.6 dB, characteristic ±0.9 dB, characteristic ±1.2 dB, characteristic ±1.5 dB, characteristic ±1.8 dB, characteristic ±2.1 dB, characteristic

Tracking Generator Output Accuracy 50 Ω (Option 1DN)

Relative Accuracy (Referred to 0 dBm) =
Output Attenuator Accuracy + Vernier Accuracy + Output Flatness

Absolute Accuracy =
Relative Accuracy (Referred to 0 dBm) + Absolute Accuracy at 50 MHz

Tracking Generator Output Accuracy 75 Ω (Option 1DQ)

Relative Accuracy (Referred to +42.75 dBmV) =
Output Attenuator Accuracy + Vernier Accuracy + Output Flatness

Absolute Accuracy =
Relative Accuracy (Referred to +42.75 dBmV) + Absolute Accuracy at 50 MHz

General

	Specifications	Supplemental Information
Temperature Range		
Operating	0 to 55 °C	Floppy disk 10 to 40 °C
Storage	-40 to 75 °C	

	Specifications	Supplemental Information
Audible Noise (ISO 7779)		
Sound Pressure at 25 °C		<40 dBa, (<4.6 Bels power)

	Specifications	Supplemental Information
Military Specification	Has been type tested to the environmental specifications of MIL-PRF-28800F class 3.	

	Specifications	Supplemental Information
EMI Compatibility	Conducted and radiated emission is in compliance with CISPR Pub. 11/1990 Group 1 Class A.	

	Specifications	Supplemental Information
Immunity Testing		
Radiated Immunity		Testing was done at 3 V/m according to IEC 801-3/1984. When the analyzer tuned frequency is identical to the immunity test signal frequency, there may be signals of up to -60 dBm displayed on the screen.
Electrostatic Discharge		Air discharges of up to 8 kV were applied according to IEC 801-2/1991. Discharges to center pins of any of the connectors may cause damage to the associated circuitry.

	Specifications	Supplemental Information
Power Requirements		
ac Operation		
Voltage, frequency	90 to 132 Vrms, 47 to 440 Hz 195 to 250 Vrms, 47 to 66 Hz	
Power Consumption, On	<300 W	
Power Consumption, Standby	<5 W	
dc Operation		
Voltage	12 to 20 Vdc	
Power Consumption	<200 W	

	Specifications	Supplemental Information
Measurement Speed		
Local Measurement and Display Update rate ^{a,b}		≥ 35/s, characteristic
Remote Measurement and GPIB Transfer Rate ^{b,c,d} (Option A4H)		≥ 30/s, characteristic
RF Center Frequency Tune, Measure, and GPIB Transfer Time ^{b,c,e} (Option A4H)		≤ 90 ms, characteristic

- a. Factory preset, auto align Off, fixed center frequency, RBW = 1 MHz, and spans >102 MHz and ≤400 MHz.
- b. Sweeping through 425.6 MHz or 914.6 MHz will cause the measurement speed to degrade.
- c. Display Off (:DISPlay:ENABle OFF), and 32-bit integer data format (:FORMat:DATA INT,32), if Option A4J is installed, disable sweep ramp, (:SYSTem:PORTs:IFVSweep:ENABle OFF), markers off, single sweep, measured with IBM compatible PC with 550 MHz Pentium® III running Windows® NT 4.0, one meter GPIB cable, National Instruments PCI-GPIB card and NI-488.2 DLL.
- d. Factory preset, auto align Off, RBW = 1 MHz, span= 20 MHz, fixed center frequency, average of 100 measurements.
- e. Factory preset, auto align Off, RBW = 1 MHz, span= 20 MHz, and center frequency tune step size = 50 MHz.

	Specifications	Supplemental Information
Data Storage		
Internal		200 Traces or States
External (10 to 40 °C) 3.5" 1.44 MB, MS-DOS® compatible floppy disk		200 Traces or States

	Specifications	Supplemental Information
Demod Tune and Listen		
Demod <i>(Option A4J)</i>	AM	Internal speaker, front-panel earphone jack and front-panel volume control. An uncalibrated demodulated signal is available on the AUX VIDEO OUT connector at the rear panel.

	Specifications	Supplemental Information
Weight (without options)		
Net		13.2 kg (29.1 lb), characteristic
Shipping		25.1 kg (55.4 lb), characteristic

Dimensions

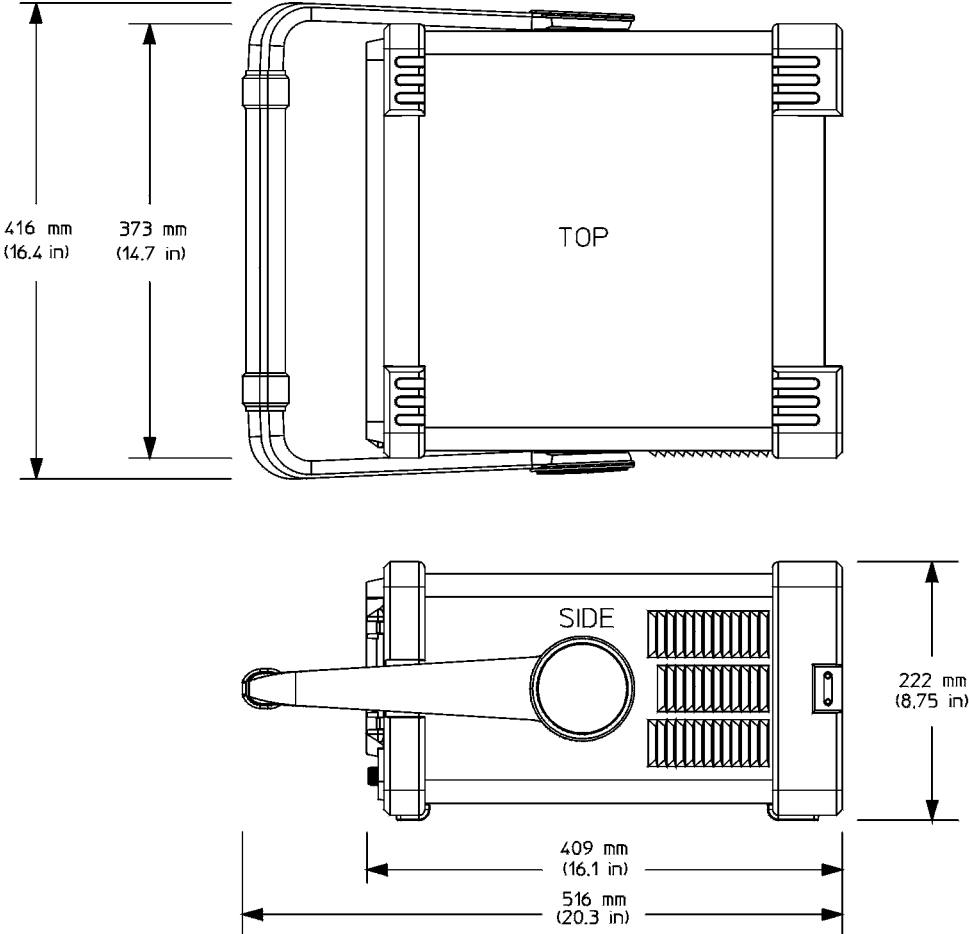

n1742a

Inputs and Outputs

Internal

	Specifications	Supplemental Information
Amptd Ref^a		Amplitude reference
Frequency		50 MHz
Frequency Accuracy		Frequency reference error ^b
50 Ω Amplitude		-25 dBm ^c , nominal
75 Ω Amplitude (<i>Option 1DP</i>)		+28.75 dBmV ^c , nominal

- Turn the amplitude reference signal on/off by pressing the keys: **Input/Output**, **Amptd Ref**.
- Frequency reference error = (aging rate \times period of time since adjustment + settability + temperature stability).
- The internal amplitude reference actual power is stored internally.

Front Panel

	Specifications	Supplemental Information
INPUT 50 Ω		
Connector	Type-N female	
Impedance		50 Ω , nominal
INPUT 75 Ω (<i>Option 1DP</i>)		
Connector	BNC female	
Impedance		75 Ω , nominal

	Specifications	Supplemental Information
RF OUT 50 Ω, (<i>Option 1DN</i>)		
Connector	Type-N female	
Impedance		50 Ω , nominal
RF OUT 75 Ω, (<i>Option 1DQ</i>)		
Connector	BNC female	
Impedance		75 Ω , nominal

	Specifications	Supplemental Information
PROBE POWER Voltage/Current		+15 Vdc, $\pm 7\%$ at 150 mA max., characteristic -12.6 Vdc $\pm 10\%$ at 150 mA max., characteristic

	Specifications	Supplemental Information
EXT KEYBOARD^a Connector	 6-pin mini-DIN	Used for entering screen titles and filenames only. Interface compatible with most IBM-compatible PC keyboards.

a. The feature is not implemented in firmware revisions prior to A.04.00.

	Specifications	Supplemental Information
Speaker		Front panel knob controls volume

	Specifications	Supplemental Information
Headphone Connector Power Output	 3.5 mm (1/8 inch) miniature audio jack	Front panel knob controls volume 0.2 W into 4 Ω , characteristic

Rear Panel

	Specifications	Supplemental Information
10 MHz REF OUT Connector Impedance Output Amplitude	 BNC female	 50 Ω , nominal >0 dBm, characteristic

	Specifications	Supplemental Information
10 MHz REF IN		
Connector	BNC female	Note: Analyzer noise sidebands and spurious response performance may be affected by the quality of the external reference used.
Impedance		50 Ω, nominal
Input Amplitude Range		-15 to +10 dBm, characteristic
Frequency		10 MHz, nominal

	Specifications	Supplemental Information
GATE TRIG/EXT TRIG IN		
Connector	BNC female	
External Trigger Input		
Trigger Level		Selectable positive or negative edge initiates sweep in EXT TRIG mode (5 V TTL)

	Specifications	Supplemental Information
GATE/HI SWP OUT		
Connector	BNC female	
High Sweep Output		
Level		High = sweep ^a ; Low = retrace (5 V TTL)

a. High sweep may be high longer than the indicated sweep times.

	Specifications	Supplemental Information
VGA OUTPUT		
Connector	VGA compatible, 15-pin mini D-SUB	
Format		VGA (31.5 kHz horizontal, 60 Hz vertical sync rates, non-interlaced) Analog RGB
Resolution	640 × 480	

	Specifications	Supplemental Information
AUX IF OUT <i>(Option A4J)</i> Connector Frequency Amplitude (for signal at reference level and for reference levels – input attenuation of –10 to –70 dBm) Impedance	BNC female	21.4 MHz, nominal –10 dBm (uncorrected), characteristic 50 Ω, nominal

	Specifications	Supplemental Information
AUX VIDEO OUT <i>(Option A4J)</i> Connector Amplitude Range (into >10 kΩ)	BNC female	0 to 1 V (uncorrected), characteristic

	Specifications	Supplemental Information
HI SWP IN <i>(Option A4J)</i> Connector Input	BNC female	Open collector, low resets and holds the sweep (5 V TTL)

	Specifications	Supplemental Information
HI SWP OUT <i>(Option A4J)</i> Connector Output	BNC female	High = sweep ^a , Low = retrace (5 V TTL)

a. High sweep may be high longer than the indicated sweep times.

	Specifications	Supplemental Information
SWP OUT <i>(Option A4J)</i>		
Connector	BNC female	
Amplitude		0 to +10 V ramp, characteristic

	Specifications	Supplemental Information
GPIB Interface <i>(Option A4H)</i>		
Connector	IEEE-488 bus connector	
GPIB Codes		SH1, AH1, T6, SR1, RL1, PP0, DC1, C1, C2, C3 and C28

	Specifications	Supplemental Information
Serial Interface <i>(Option 1AX)</i>		
Connector	9-pin D-SUB male	RS-232

	Specifications	Supplemental Information
Parallel Interface <i>(Option A4H or 1AX)</i>		Printer port only
Connector	25-pin D-SUB female	

Regulatory Information

CAUTION

This product is designed for use in Installation Category II and Pollution Degree 2 per IEC 1010 and 664 respectively.

NOTE

This product has been designed and tested in accordance with IEC Publication 1010, Safety Requirements for Electronic Measuring Apparatus, and has been supplied in a safe condition. The instruction documentation contains information and warnings which must be followed by the user to ensure safe operation and to maintain the product in a safe condition.



The CE mark is a registered trademark of the European Community (if accompanied by a year, it is the year when the design was proven).



The CSA mark is the Canadian Standards Association safety mark.

ISM 1-A

This is a symbol of an Industrial Scientific and Medical Group 1 Class A product. (CISPR 11, Clause 4)

Declaration of Conformity

DECLARATION OF CONFORMITY

According to ISO/IEC Guide 22 and CEN/CENELEC EN 45014

Manufacturer's Name: Agilent Technologies, Inc.

Manufacturer's Address: 1400 Fountaingrove Parkway
Santa Rosa, CA 95403-1799
USA

Declares that the products

Product Name: Spectrum Analyzer

Model Number: E4401B, E4402B, E4403B, E4404B,
E4405B, E4407B, E4408B, E4411B

Product Options: This declaration covers all options of the above products.

Conform to the following product specifications:

EMC: IEC 61326-1:1997+A1:1998 / EN 61326-1:1997+A1:1998

<u>Standard</u>	<u>Limit</u>
CISPR 11:1990 / EN 55011-1991	Group 1, Class A
IEC 61000-4-2:1995+A1998 / EN 61000-4-2:1995	4 kV CD, 8 kV AD
IEC 61000-4-3:1995 / EN 61000-4-3:1995	3 V/m, 80 - 1000 MHz
IEC 61000-4-4:1995 / EN 61000-4-4:1995	0.5 kV sig., 1 kV power
IEC 61000-4-5:1995 / EN 61000-4-5:1996	0.5 kV L-L, 1 kV L-G
IEC 61000-4-6:1996 / EN 61000-4-6:1998	3 V, 0.15 – 80 MHz
IEC 61000-4-11:1994 / EN 61000-4-11:1998	1 cycle, 100%

Safety: IEC 61010-1:1990 + A1:1992 + A2:1995 / EN 61010-1:1993 +A2:1995
CAN/CSA-C22.2 No. 1010.1-92

Supplementary Information:

The products herewith comply with the requirements of the Low Voltage Directive 73/23/EEC and the EMC Directive 89/336/EEC and carry the CE-marking accordingly.



Santa Rosa, CA, USA 17 April 2000

Greg Pfeiffer/Quality Engineering Manager

For further information, please contact your local Agilent Technologies sales office, agent or distributor.